



Instruction Manual

Product Manual & Specification

AG Dispenser models



AG Maxi

Garnett Farms Engineering Limited

Clay Bank Farm, Allostock, Nr. Knutsford,
Cheshire, WA16 9NE
England, UK

Tel: +44 (0)1565 722922 Fax: +44 (0)1565 723303
Website : www.ag-products.co.uk Email : info@ag-products.co.uk

REVISIONS			
NO.	DATE	DESCRIPTION	APPROVED

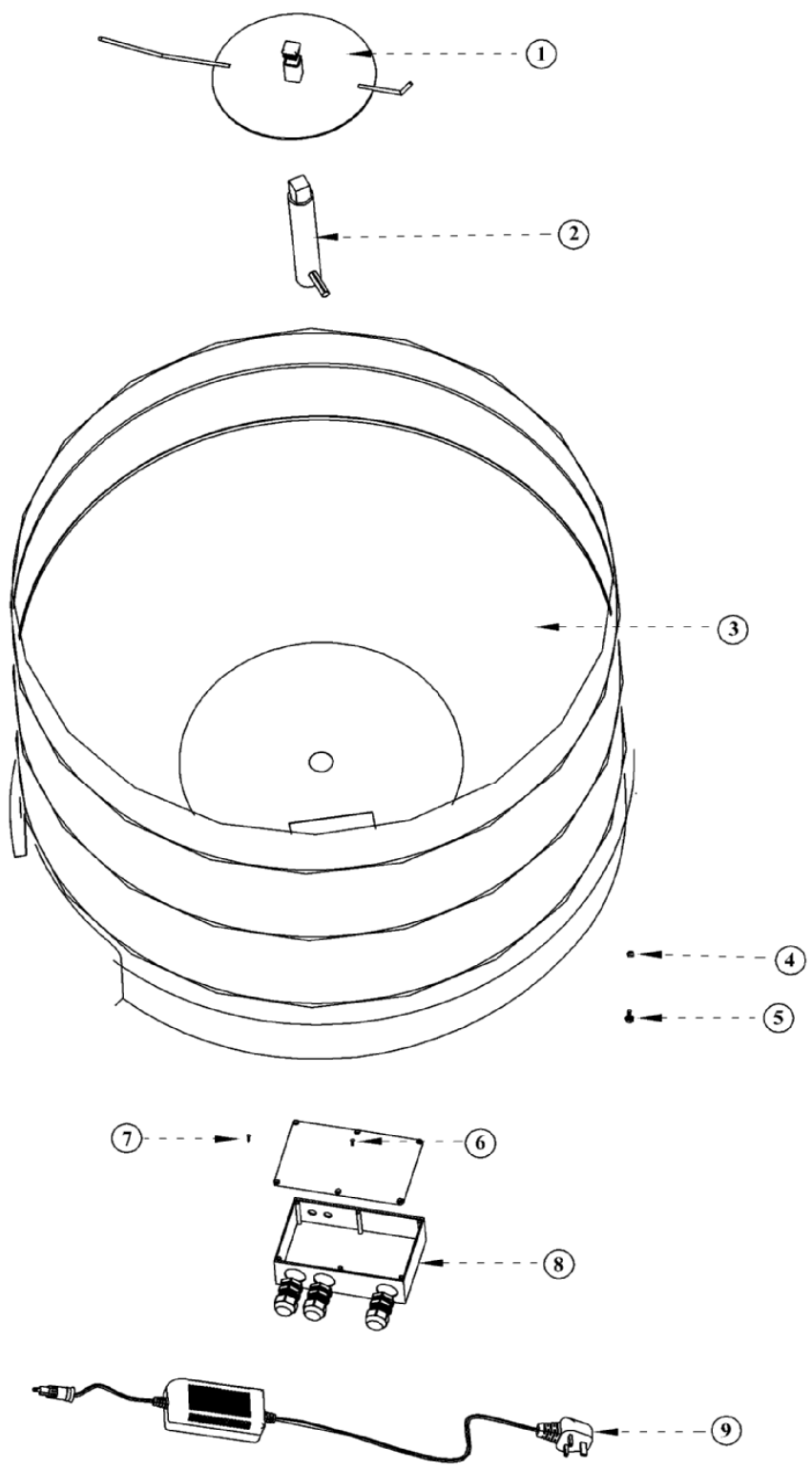

FILE NAME	AG MAXI
CONTRACT NO	-----
ISSUED BY	ISSUED BY
CHECKED	CHECKED
APPROVED	APPROVED
ISSUED	ISSUED
SIZE	SIZE
SCALE	SCALE
WEIGHT	WEIGHT
SHEET	SHEET
REV	REV

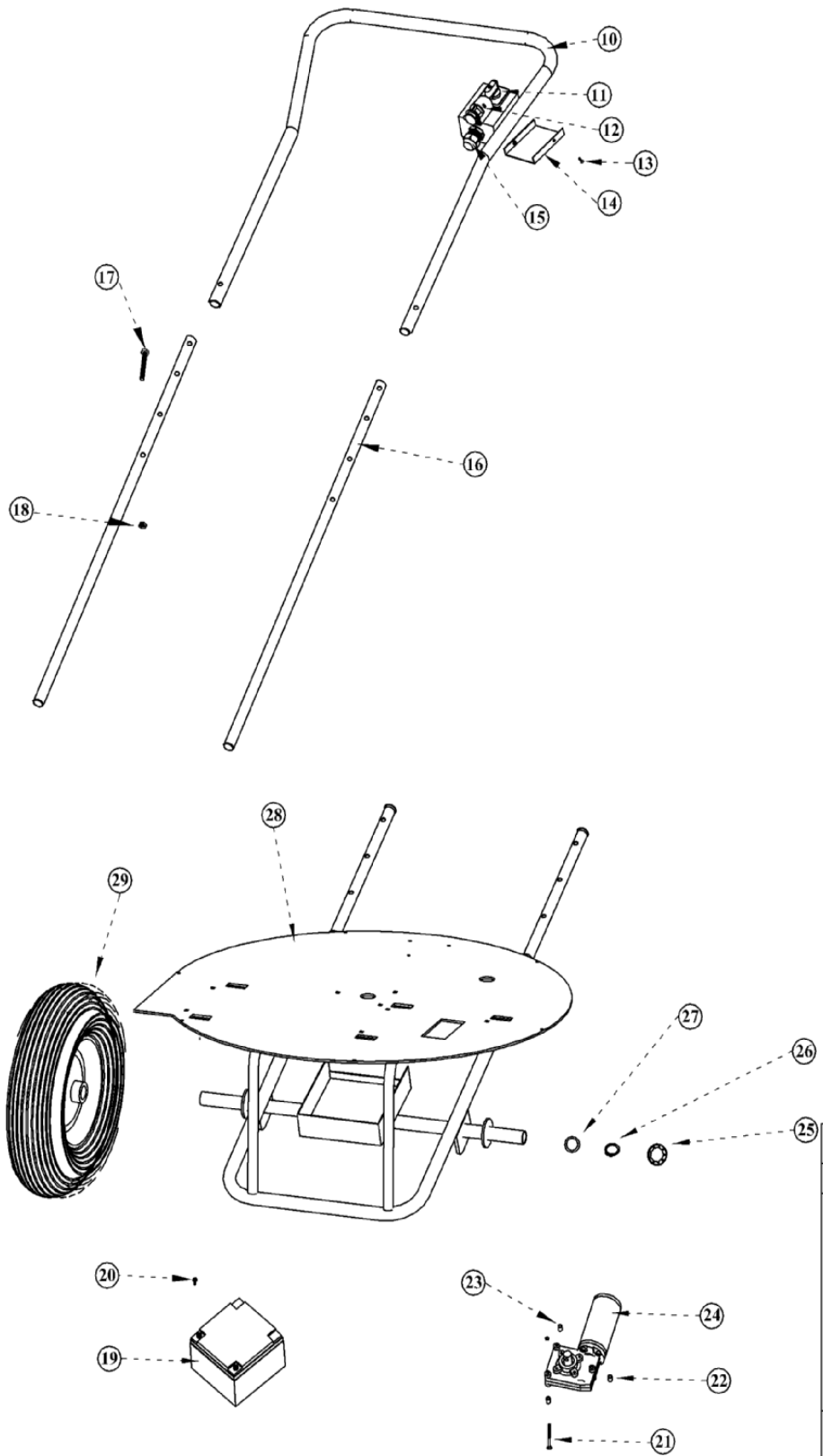

FILE NAME	AG MAXI
CONTRACT NO.	
DRAWN	JAMES WORTH
CHECK	AJ GARNETT
APPR.	AJ GARNETT
ISSUED	24/05/07
SCALE	
SIZE	
WEIGHT	
SHEET	
REV	

REVISIONS		DATE	APPROVED
ZONE	REV		

AG MAXI BASE

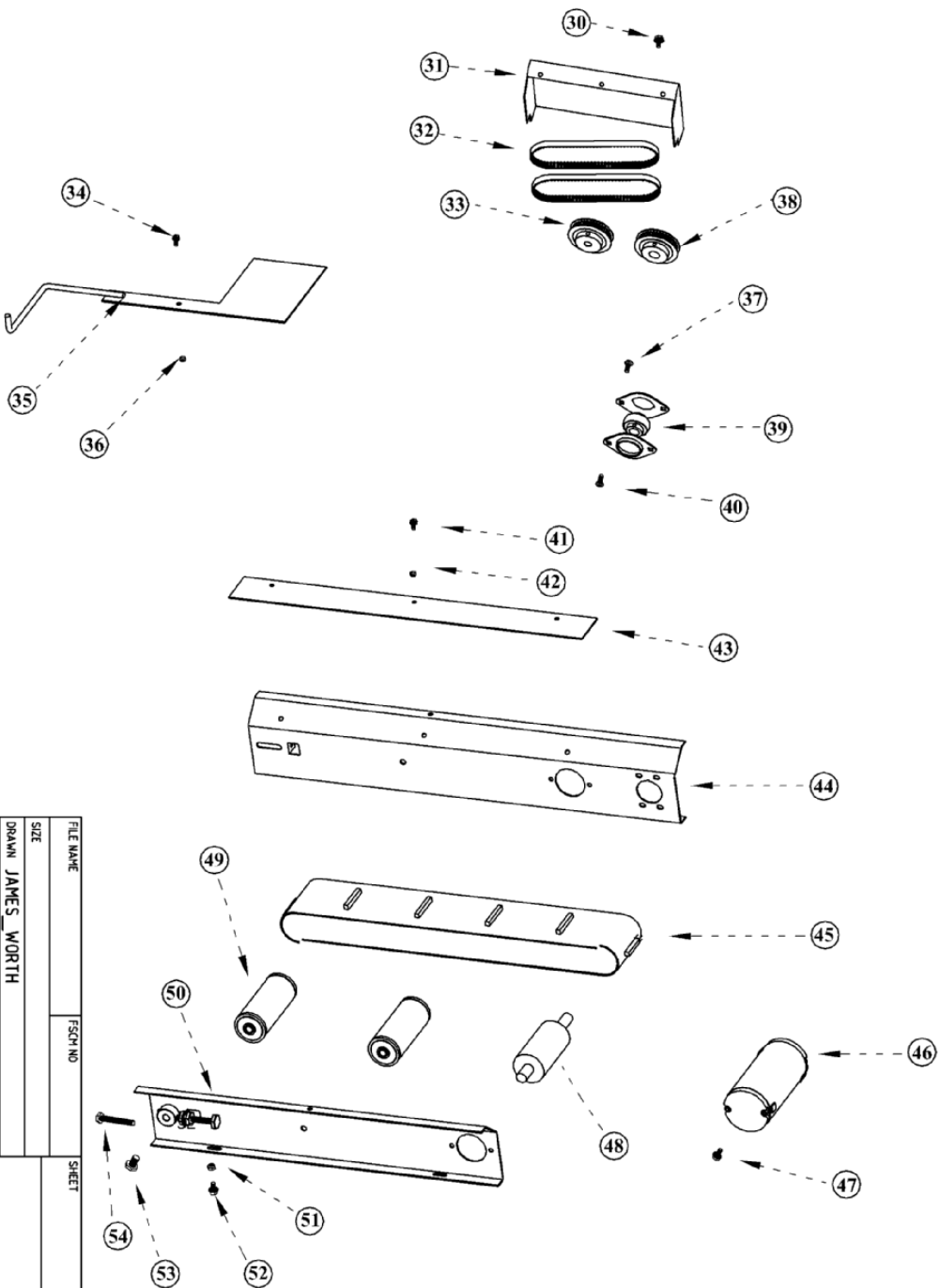

FILE NAME	FSCH NO	SHEET	SCALE
SIZE			
DRAWN	JAMES MORTH		AGMAXI
CHECK	AJ GARNETT		
APPR.	AJ GARNETT		
ISSUED			
REV		DWG NO	
CONTRACT NO			

AG Maxi Wiring Diagram

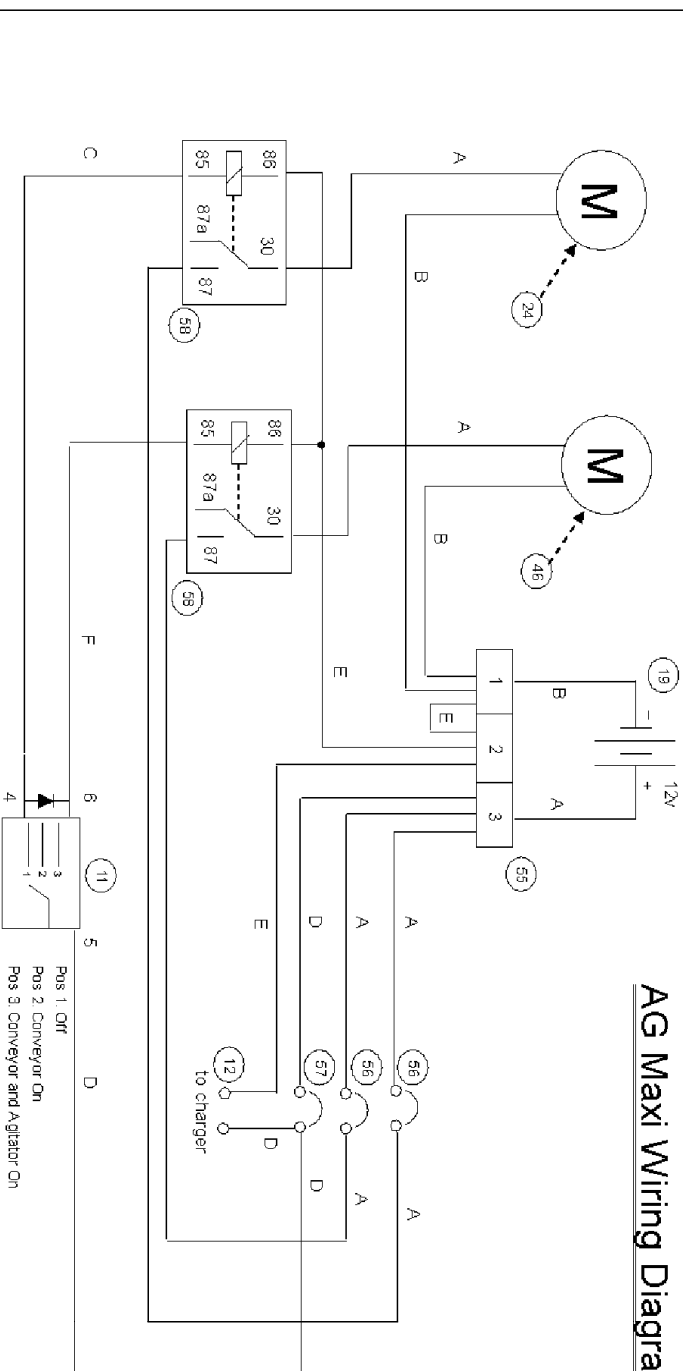

Wiring Code

- A Red 4mm Diameter
- B Black 4mm Diameter
- C Yellow 2mm Diameter
- D Red 2mm Diameter
- E Black 2mm Diameter
- F Grey 2mm Diameter

Parts List

- 11 Selector Switch (with rectifier IN5408)
- 12 Charger Port
- 19 Battery 12V 26AH
- 24 Agilator Motor
- 46 Conveyor Motor
- 55 Terminal Block
- 56 Motor Circuit Breakers, 35A
- 57 Charger Circuit Breaker, 5A
- 58 Motor Relays, 40A

Wiring of Switch

- bypass wire on terminals 5 and 3
- bypass wire on terminals 1 and 3
- rectifier between terminals 8 and 6
- terminal 4 to relay 85 (agilator) wire C
- terminal 6 to relay 85 (conveyor) wire F

Pos 1. OFF
 Pos 2. Conveyor On
 Pos 3. Conveyor and Agilator On

Revision 1:	
Revision 2:	
Revision 3:	
Revision 4:	
Client:	
Job Title:	
Drawn No.:	Scale:
XXXXXXXXXX	XXXXXXXXXX
Date:	Drawn:
XXXXXXXXXX	XXXXXXXXXX
Office: Garnett Farms Engineering Claybank Farm Allostock Knustford Cheshire WA16 9NE TEL: 01 953 72988 FAX: 01 953 72905	

Garnett Farms Engineering Limited

Clay Bank Farm, Allostock, Nr Knutsford, Cheshire WA16 9NE Tel: 01565 722 922 Fax: 01565 723303

Machine	ITEM NO.	QUANTITY REQUIRED	PART NO.	DESCRIPTION
MAXI	1	1	MC2-18-1	AGITATOR
MAXI	2	1	MC2-17-1	AGITATOR SHAFT
MAXI	3	1	MC2-02	DRUM
MAXI	4	8	MC2-23	M5 NUT
MAXI	5	8	MC2-24-2	M5* 12mm BOLT
MAXI	6	6	MC3-01-3	M4 * 10mm SCREW
MAXI	7	3	MC3-01-4	Diameter 3* 16mm SCREW
MAXI	8	1	MC2-19	BREAKER BOX
MAXI	9	1	MC3-04-7	CHARGER YCB4A12
MAXI	10	1	MC2-04-1	UPPER HANDLE
MAXI	11	1	MC3-04-5	CAM SWITCH ASSEMBLY
MAXI	12	1	MC3-04-8	CHARGER PORT
MAXI	13	2	MC3-01-3	M4 * 10mm SCREW
MAXI	14	1	MC3-04-9	SWITCH GEAR COVER
MAXI	15	1	MC3-02-1	GROMMIT
MAXI	16	2	MC2-03	LOWER HANDLE
MAXI	17	2	MC3-01-5	M8* 60mm BOLT
MAXI	18	2	MC3-01-6	M8 NUT
MAXI	19	1	MC2-02-1	BATTERY NP2412R
MAXI	20	2	MC3-01-2	M5 * 12mm BOLT
MAXI	21	3	MC3-01-7	M6 * 70mm BOLT
MAXI	22	3	MC3-02-2	SPACER
MAXI	23	3	MC3-01-1	M6 NUT
MAXI	24	1	MC2-20	MOTOR (PM50-63-2-12V-GB:4 50:1) AGITATOR
MAXI	25	2	MC3-06-1	WHEEL CAP
MAXI	26	2	MC3-06-2	WHEEL CIR CLIP
MAXI	27	2	MC3-06-3	WHEEL WASHER
MAXI	28	1	MC2-01-1	MAIN FRAME
MAXI	29	2	MC3-06-4	WHEEL
MAXI	30	3	MC3-01-8	M6 * 12mm BOLT
MAXI	31	1	MC2-15	TIMING BELT COVER
MAXI	32	2	MC2-14	TIMING BELT (BT5/450/10)
MAXI	33	1	MC2-12	PULLEY (38T5-15-S16)
MAXI	34	1	MC3-01-2	M5 * 12mm BOLT
MAXI	35	1	MC2-16	ADJUSTER PLATE
MAXI	36	1	MC2-23	M5 NUT
MAXI	37	2	MC3-01-9	M6 * 16mm CUPSQUARE BOLT
MAXI	38	1	MC2-13	PULLEY (38T5-15-S09)
MAXI	39	2	MC2-09	BRG SLFE16
MAXI	40	2	MC3-01-9	M6 * 16mm CUPSQUARE BOLT
MAXI	41	6	MC3-01-8	M6 * 12mm BOLT
MAXI	42	6	MC3-01-1	M6 NUT
MAXI	43	2	MC2-11	SIDE SKIRT PLATE
MAXI	44	1	MC2-06-1	CONVEYOR DRIVE SIDE
MAXI	45	1	MC2-05	CONVEYOR BELT
MAXI	46	1	MC2-22	MOTOR PM50-63-2-12V CONVEYOR
MAXI	47	4	MC3-01-8	M6 * 12mm BOLT
MAXI	48	1	MC2-8	HEAD ROLLER
MAXI	49	2	MC2-7	IDLER ROLLER
MAXI	50	1	MC2-06-2	CON SIDE
MAXI	51	4	MC3-01-8	M6 * 12mm BOLT
MAXI	52	4	MC3-01-1	M6 NUT
MAXI	53	6	MC3-01-11	M10 * 16mm BOLT
MAXI	54	2	MC3-01-5	TENSIONER BOLT M8 * 60
MAXI	55	1	MC3-04-1	TERMINAL BLOCK
MAXI	56	2	MC3-04-3	CIRCUIT BREAKER MOTOR/AGITATOR (40 ampere)
MAXI	57	1	MC3-04-4	CHARGING BREAKER (5 ampere)
MAXI	58	2	MC3-04-6	RELAY 1 (40 ampere)
MAXI		1	MC3-05-1	PRODUCT MANUAL
MAXI		1	MC3-05-2	PULLEY - LIME 25T5-15+S09
MAXI		2	MC3-05-3	PULLEY V-BELT BT5/420/10
MAXI			MC3-05-5	TRI WHEELS