



AG Products

— AG DUO —
OPERATION MANUAL

Released Jul 2023

www.ag-products.co.uk

+44 (0) 1565 722922

Contents

1	INTRODUCTION.....	1
1.1	FOREWORD.....	1
1.2	SAFETY.....	1
1.2.1	SAFETY PRINCIPLES.....	1
1.2.2	INTENDED USE.....	2
1.2.3	MISUSE.....	2
1.2.4	SAFETY SIGNS.....	3
1.2.5	ISOLATING THE AG DUO.....	5
1.2.6	APPLYING THE PARKING BRAKE.....	6
1.2.7	EMERGENCY STOP.....	7
1.2.8	TRANSPORT AND LIFTING.....	8
1.2.9	BEFORE OPERATING THE AG DUO.....	11
1.2.10	WHEN OPERATING THE AG DUO.....	11
1.2.11	WHEN SERVICING AND ADJUSTING THE AG DUO.....	12
1.2.12	ADDITIONAL SAFETY MEASURES WHEN HANDLING THE BATTERY.....	13
1.2.13	WHEN CLEANING AND STORING THE AG DUO.....	13
2	ABOUT THE AG DUO.....	14
2.1	BRUSH.....	14
2.2	AXLE.....	14
2.3	QR CODE.....	15
2.4	HOPPER COVER.....	15
2.5	SCRAPER.....	15
3	SPECIFICATIONS.....	16
3.1	OUTLINE DIMENSIONS.....	16
3.2	TECHNICAL SPECIFICATIONS.....	16
3.3	AIRBORNE NOISE EMISSIONS.....	17
3.4	MACHINE IDENTIFICATION.....	17
4	OPERATION AND SETTINGS.....	18
4.1	CHARGING THE AG DUO PRIOR TO USE.....	18
4.2	CONTROLS.....	20

4.3	ADJUSTMENTS	23
4.3.1	METERING SHUTTER	23
4.3.2	CONVEYOR AND AUGER SPEEDS.....	24
4.3.3	SWEEPING BRUSH HEIGHT.....	26
4.3.4	SWEEPING BRUSH ANGLE	28
4.4	FAULT CONDITIONS & RECOVERY.....	29
4.4.1	OVERLOAD RESET.....	29
4.4.2	BLOCKAGE REMOVAL.....	29
4.4.3	CIRCUIT BREAKER.....	30
4.4.4	EMERGENCY STOP.....	31
5	MAINTENANCE.....	32
5.1	SERVICE SCHEDULE	32
5.1.1	IN STORAGE.....	33
5.2	GREASING POINTS.....	34
5.3	CONVEYOR BELT ALIGNMENT AND ADJUSTMENT	37
5.4	CONVEYOR DRIVE BELT TENSION	39
5.5	AGITATOR AND AUGER CHAIN ADJUSTMENT.....	41
5.6	SCRAPER BLADE ADJUSTMENT	42
6	REPLACEMENT OF SERVICE ITEMS.....	43
6.1	BRUSH REPLACEMENT	43
6.2	CONVEYOR BELT REPLACEMENT.....	44
6.3	CONVEYOR ROLLER REPLACEMENT	44
6.4	CONVEYOR SIDE SKIRT REPLACEMENT	45
6.5	SCRAPER BLADE REPLACEMENT	46
6.6	SKID BLOCK REPLACEMENT.....	47
6.7	BATTERY REPLACEMENT	48
7	TROUBLESHOOTING.....	49
8	SPARE PARTS IDENTIFICATION.....	51
8.1	AGITATOR, AUGER & CHAIN DRIVE.....	52
8.2	SHUTTER.....	53
8.3	CONVEYOR	54
8.4	BRUSH & ARM.....	55
8.5	WHEELS & AXLES.....	56
8.6	BRUSH ACTUATOR	57

8.7	COVERS AND PANELS	58
8.8	SCRAPER (OPTION).....	59
8.9	ELECTRICAL.....	60
9	BATTERY CHARGER OPERATING MANUAL.....	62
10	TERMS, CONDITIONS AND WARRANTY	65
10.1	STANDARD TERMS AND CONDITIONS	65
10.2	QUALITY OF TRANSLATIONS	69
10.3	SAFETY.....	69
10.4	AG PRODUCTS DEALER WARRANTY PROCESS	71

1 INTRODUCTION

1.1 FOREWORD

Thank you for your purchase of the AG Duo.

This manual will assist the operator to set, operate and maintain the AG Duo. For safe and reliable operation, these instructions must be followed at all times. It is particularly important that the safety notes in the following section are read and understood by all users and maintainers of the machine before it is used.

1.2 SAFETY

The following safety instructions apply to all chapters of this manual.

1.2.1 SAFETY PRINCIPLES

Accident prevention programs can only prevent accidents with the co-operation of the persons responsible for the operation of the equipment.

For the safety of yourself and others, operate equipment with care and do not take unnecessary risks, which could cause an accident.

Please read all safety instructions contained in this manual with the utmost care and observe all safety signs attached to the AG Duo. Please ensure these instructions are made available and understood by all other users of the AG Duo. You are strongly advised to refrain from any working methods which may be hazardous.

All relevant accident prevention regulations governing the operation of agricultural machinery, as well as other generally acknowledged health and safety regulations must be strictly observed.

CAUTION



This symbol will appear throughout this manual whenever your safety or the safety of others is involved.

1.2.2 INTENDED USE

The AG Duo is intended for single operator use for brushing and dispensing bedding materials into cattle cubicles.

1.2.3 MISUSE



Foreign objects, such as stones and metal objects, must not be allowed to enter the AG Duo. Failure to observe this may result in damage to the machine and/or injury to the operator or others.

Do not ride on the AG Duo or permit others to do so.

Do not attempt to run the AG Duo with any of the covers or guards removed.

Do not attempt to modify the AG Duo or the wiring.

Do not attempt to operate the machine outside the specifications without reference to Garnett Farms Engineering Ltd or an authorised distributor.

Misuse also comprises failure to observe the instructions as given in this manual and the recommended maintenance and service requirements.

Do not tow the AG Duo.

1.2.4 SAFETY SIGNS

The following signs appear on the machine and are for your safety and the safety of other people. Ensure that you identify each symbol and understand its warning.



All safety signs must be kept in a legible condition and must be replaced if damaged or missing.

Safety signs used.



Switch off power and remove the isolator switch



Keep a safe distance from the machine to avoid injury



Don't reach into the hopper/gain access into the hopper due to the danger of rotating parts



Risk of electric shock from overhead power lines when lifting the machine



Danger of entrapment



Ear protection is advised



Read and understand this manual before operating the machine



Use of a dust mask is advised



Return used batteries to Garnett Farms Engineering Ltd or an authorised distributor for disposal.

The safety signs are located on the AG Duo in the following places:



1.2.5 ISOLATING THE AG DUO



Electrically isolating the AG Duo is the **only** way to ensure it cannot be started unexpectedly. The isolator switch disconnects electrical power to the whole machine.

DO NOT USE THE EMERGENCY STOP AS A METHOD FOR ISOLATING THE AG DUO.

It is recommended that the AG Duo is isolated and the isolator switch removed whenever the AG Duo is not in use to prevent unauthorised use, for example by untrained personnel.

The AG Duo must be isolated on any occasion which involves manual intervention within the AG Duo, such as clearing jams, routine maintenance or parts replacement, or in any other similar circumstance.

ob

Turn counterclockwise to isolate the AG Duo. Pull the isolator switch to remove.

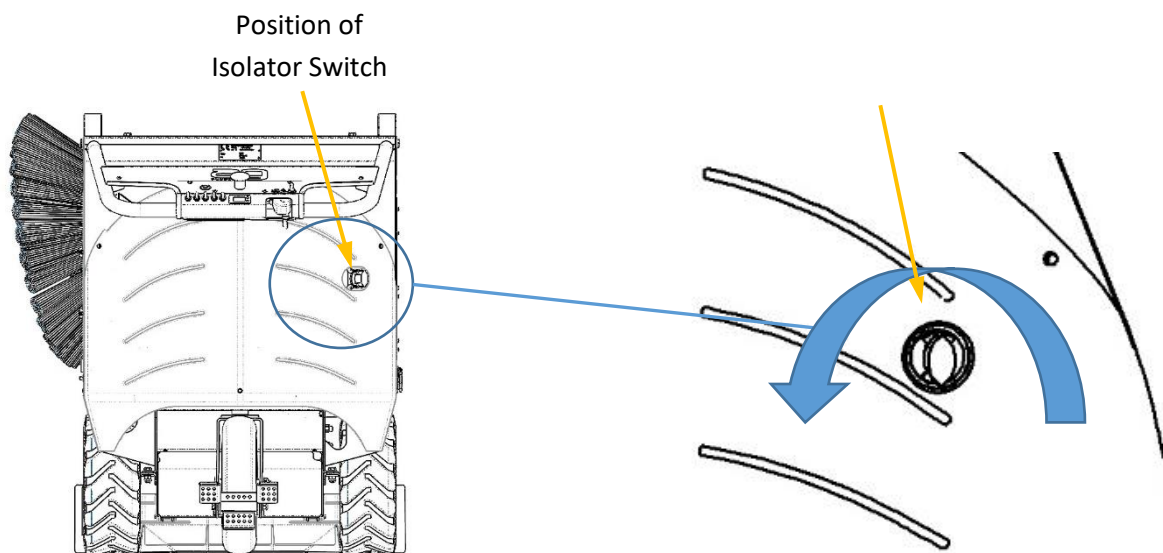

1.2.6 APPLYING THE PARKING BRAKE

In addition to isolating the machine, the parking brake should be applied whenever the AG Duo is not in use to prevent unauthorised use, for example by untrained personnel. This is particularly important on sloping or uneven ground. The parking brake is foot operated.

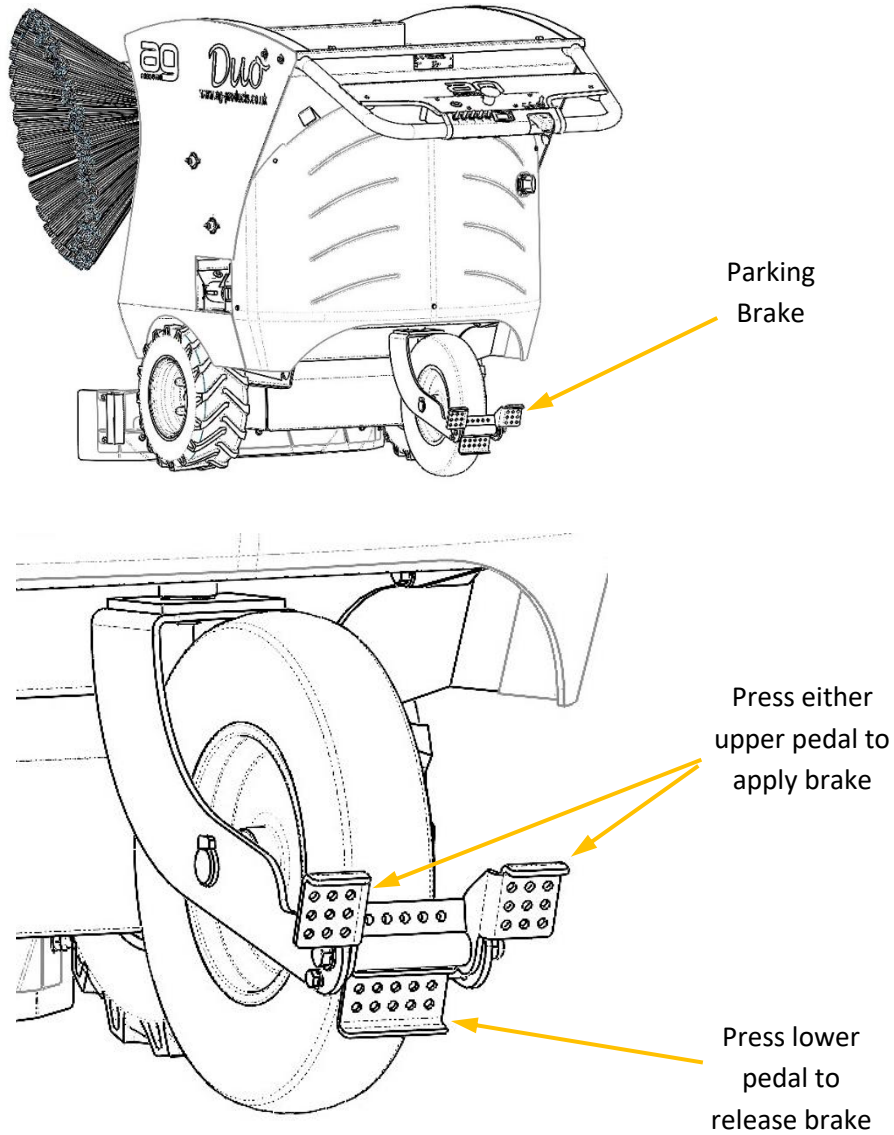

1.2.7 EMERGENCY STOP

An emergency stop is provided to halt all the elements of the AG Duo should the occasion arise.

The emergency stop should not be used to stop the AG Duo in normal operation.

To restart the AG Duo after the application of the emergency stop, the stop button should be lifted and the reset button pressed.

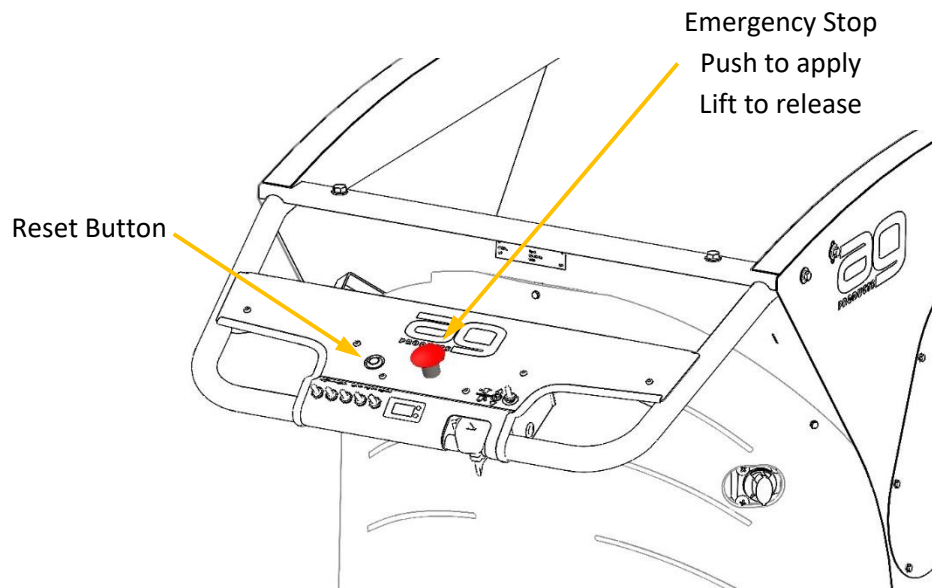

Note also that the reset button must also be pressed whenever the AG Duo is powered up.

1.2.8 TRANSPORT AND LIFTING



- Always isolate the AG Duo before transporting or lifting.
- Ensure bystanders are at a safe distance when moving the AG Duo.
- Ensure all slings, chains or other lifting and moving devices are suitable and tested for the weight of the AG Duo as defined in Section 3: Specifications
- Take care to avoid overhead power lines when lifting the AG Duo. 
- DO NOT TOW THE AG DUO
- The Brush arm should be secured in its upright position before transport. Proceed as follows:
 - Note the position of the chassis lug.
 - Ensure that the brush arm is fully upright.
 - Release the lynchpin and pull the linkage pivot out, taking care that the brush arm does not fall down.
 - Rotate the linkage pivot and push back in so that it engages with the chassis lug.
 - Re-fit the lynchpin.

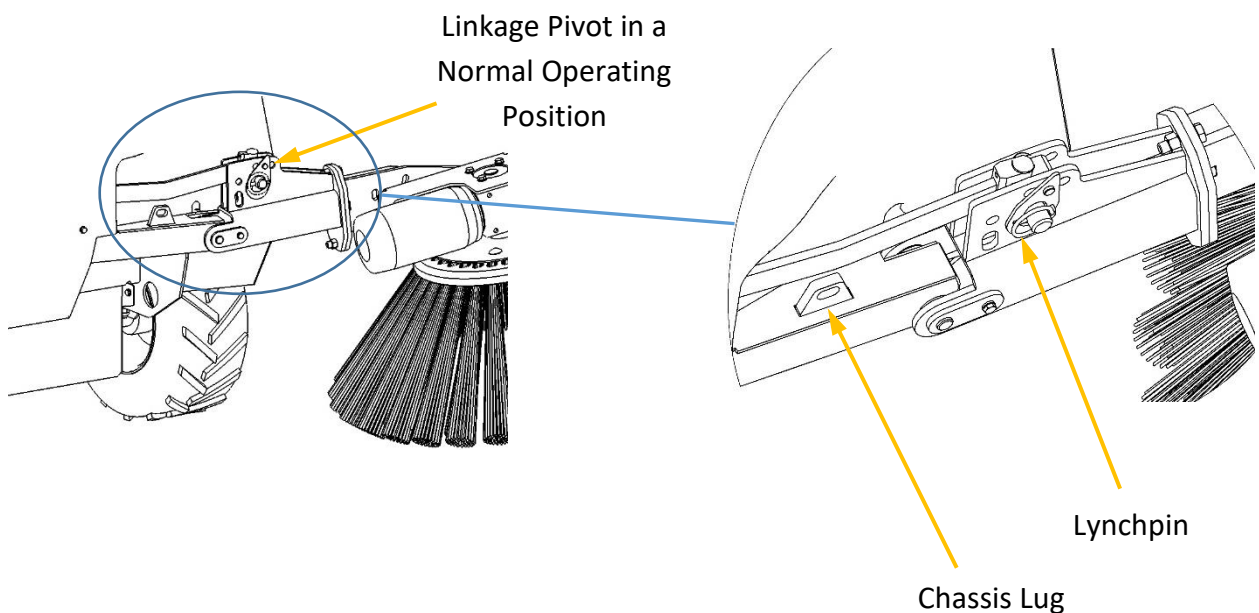

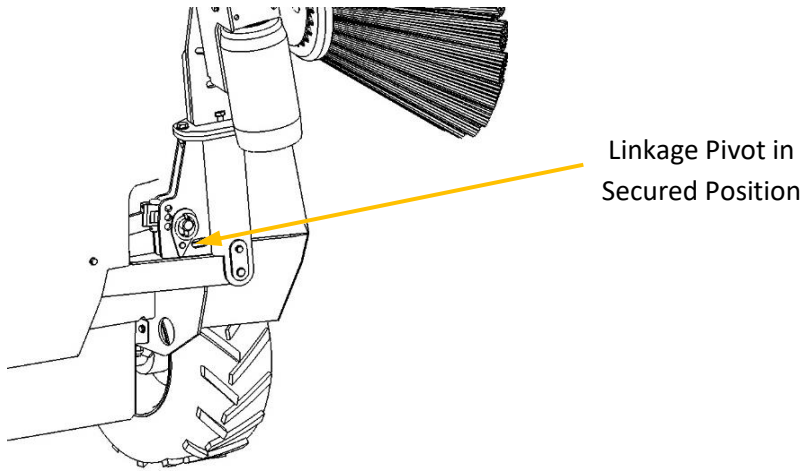

The AG Duo should be transported by one of the following methods only:

1. Using a trailer with appropriate ramps to allow the machine to be driven onto it. Once on the trailer, the machine should be secured by using the securing points on the machine chassis with straps also around the main axle, between the wheels and the chassis.

The parking brake should also be applied.

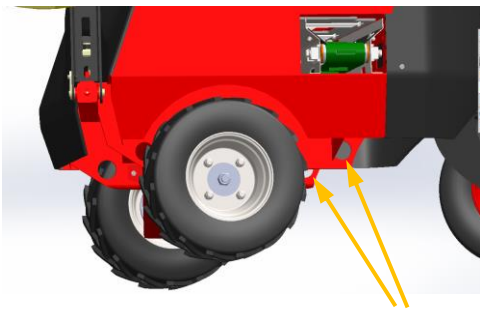

2. Using overhead lifting by slinging the AG Duo with the dedicated lifting points.

If moving the AG Duo by overhead lifting, use the designated lifting points as identified below. Ensure that the slings/chains are rated accordingly and that the angles of the slings/chains are set in accordance with lifting regulations.

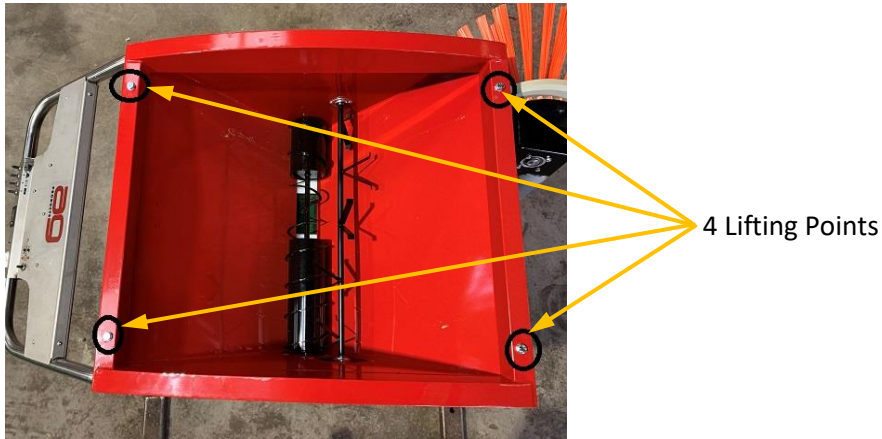

4 x M12 lifting eyes with the correct load rating will be required for overhead lifting. These are to be screwed fully into the top of the hopper once the blanking bolts have been removed (blanking bolts illustrated in the picture above).



Take care to avoid overhead power lines or other obstructions when lifting the AG Duo.

1.2.9 BEFORE OPERATING THE AG DUO



Ensure that you are conversant with the contents of this manual, particularly the safety requirements.

The AG Duo should only be used if all safety devices, e.g. detachable guards, parking brake, emergency stop etc. are secure and in good order.

Check there are no foreign objects within the AG Duo and inspect bedding material before loading to ensure it does not contain any foreign objects.

Charge the battery fully. See Section 4.1.

Ensure that no person is working on, inside or in the local area of the AG Duo, at any time during all stages of use. Ensure your driving line is free from obstructions and bystanders.

Always perform a walk-round inspection before starting the machine.

1.2.10 WHEN OPERATING THE AG DUO



The AG Duo must not be put into operation until all users have read and understood this manual. If in any doubt, contact your dealer or AG Products.

The AG Duo is for single-person use. If the operator identifies someone approaching or is too close for their safety, the operator should stop the machine until the person is clear before starting again.

Bystanders need to keep a safe distance from the AG Duo while it is being used. Warn bystanders and give them time to move before starting.

In the event of a malfunction, stop the AG Duo immediately and secure in a stationary position. All malfunctions must be rectified immediately.

Do not work around the AG Duo in loose clothing that might get caught up in moving parts. Do not work under the AG Duo unless it is securely chocked **and** secured with the parking brake.

Always replace all guards after making any adjustments to the AG Duo. Replace any missing or damaged guards immediately.

Never approach the AG Duo whilst the machine is being operated.

Keep hands and feet away from moving parts, i.e. conveyor belt, auger, top agitator, brush or scraper (if fitted). Do not reach into the bin due to the danger of entanglement with the auger and agitator.

If manually loading the bin, follow manual handling recommendations. Refer to HSE guidelines:

<https://www.hse.gov.uk/toolbox/manual.htm>

Bedding products require the use of Personal Protective Equipment (PPE) such as gloves, goggles, face masks and overalls. Please contact your bedding supplier for their recommendations.

1.2.11 WHEN SERVICING AND ADJUSTING THE AG DUO



The AG Duo must only be serviced/maintained by a competent person who understands the workings of the machine and the risks involved in carrying out this type of work.

Ensure the AG Duo is on the ground or, if in an elevated position, that it is securely supported.

Wear appropriate PPE (Personal Protective Equipment) when carrying out all maintenance or service work.

Isolate the AG Duo (see Section 1.2.5) and apply the parking brake (see Section 1.2.6) before performing any maintenance or service work.

All defects which could affect the safe operation of the AG Duo must be rectified immediately.

If running the machine during maintenance or adjustment, keep a safe distance away from moving parts. Always stop the machine before making any further adjustments and replace all guards once your work is complete.

1.2.12 ADDITIONAL SAFETY MEASURES WHEN HANDLING THE BATTERY

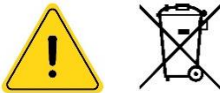

The battery is for use in the AG Duo only.

Do not use the battery if there is damage to the outer casing or wires.

Do not use the battery if there are any signs of leakage from it.

Do not tamper with the battery.

Take care when lifting or carrying the battery considering the weight (See Section 3.2).

Keep the battery substantially upright; that is with the lifting handles uppermost.

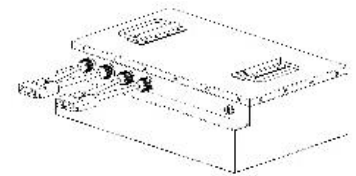

The battery should be stored in a dry environment, within a temperature range of 5-40 °C.

Isolate the AG Duo before changing the battery (See Section 1.2.5).

Only use the charger supplied with the AG Duo.

Isolate the AG Duo before connecting to the charger.

Fully charge the battery before the first use and after each use.

Return used batteries to Garnett Farms Engineering Ltd or an authorised distributor for disposal.

DO NOT INCINERATE. DO NOT DISPOSE OF IN HOUSEHOLD WASTE.

1.2.13 WHEN CLEANING AND STORING THE AG DUO



Isolate the battery before cleaning.

We recommend using compressed air to blow away any waste material and a cleaning agent on any heavily soiled areas.

Do not run the machine while cleaning.

Do not use a steam cleaner.

Wipe down with a wet cloth avoiding water from touching the battery and terminals.

Wear appropriate Personal Protective Equipment (PPE).

When storing the machine ensure the hopper and conveyor are empty of product.

2 ABOUT THE AG DUO

The AG Duo is a self-propelled bedding dispenser and cubicle brush. An optional scraper blade can be fitted. It is designed to brush old bedding and manure off cubicles and to dispense a variety of bedding products such as sawdust and EnviroBed.

The AG Duo is a fully electric machine. It consists of a driven axle, a hopper which holds the bedding product, a rotary brush for sweeping cubicles, an auger and agitator combination which moves the product within the hopper and a conveyor to dispense the product.

The AG Duo is intended for single person use. The operator has full control of the machine's speed and rate of dispensing. The driven axle, the conveyor and the auger all have independent speed controls and there is a metering shutter at the bottom of the hopper.

2.1 BRUSH

The Brush is mounted on an adjustable floating arm, allowing the brush to float over joins in mats without lifting them. This also gives the operator the ability to add more pressure onto the brush, useful for cleaning heavily soiled cubicles or cubicles that have not been mechanically swept before. The brush linkage is driven by the actuator ram. +36 V from the actuator circuit powers the ram.



2.2 AXLE

The AG Duo uses a +36 V Lithium battery to power a driven axle, reduce operator fatigue and allow for a larger capacity bin.



2.3 QR CODE

The QR code can be found on the Duo hopper, located next to the safety stickers. By scanning the code with a smartphone camera, a link will appear on screen. Click the link to access the AG Duo Operator’s manual.



2.4 HOPPER COVER

The AG Duo has a hopper cover to eliminate material wastage during transport. This cover is an optional extra.



2.5 SCRAPER

The optional scraper blade is raised and lowered independently of the other mechanisms, powered by an electric actuator. When lowered, this also floats, self-adjusting for unevenness on the floor surface. With this function added, both cubicles and passageways can be cleaned in one passing.



The major parts of the AG Duo are identified in the following diagrams:

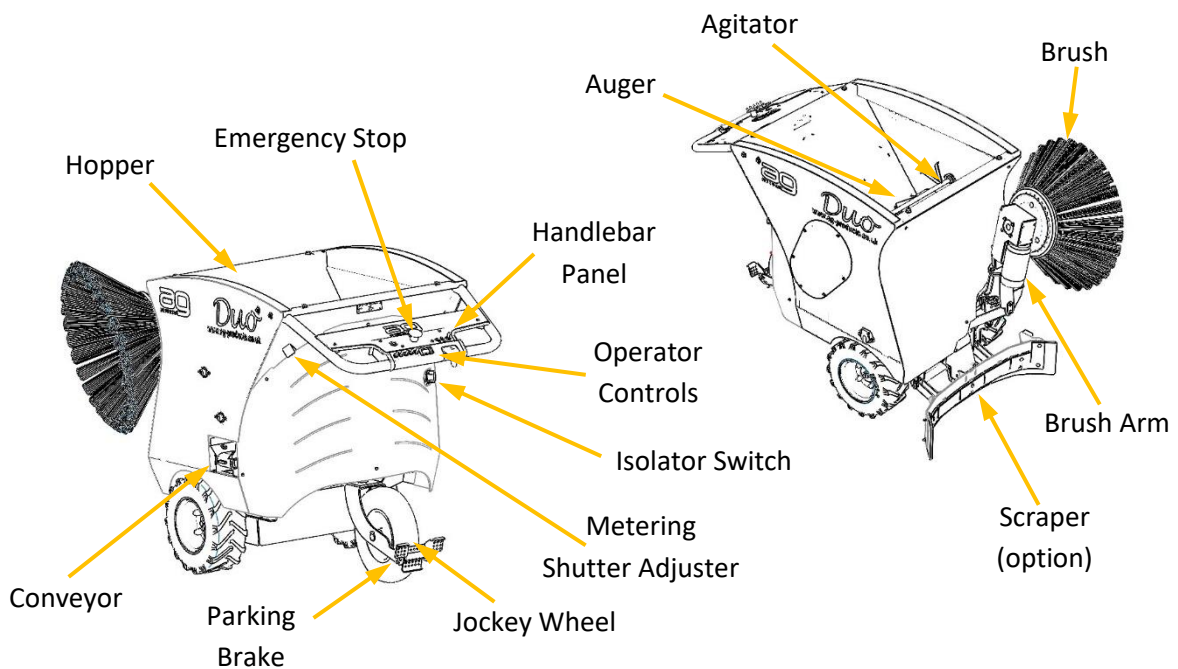

3 SPECIFICATIONS

3.1 OUTLINE DIMENSIONS

All dimensions are in mm and are approximate.

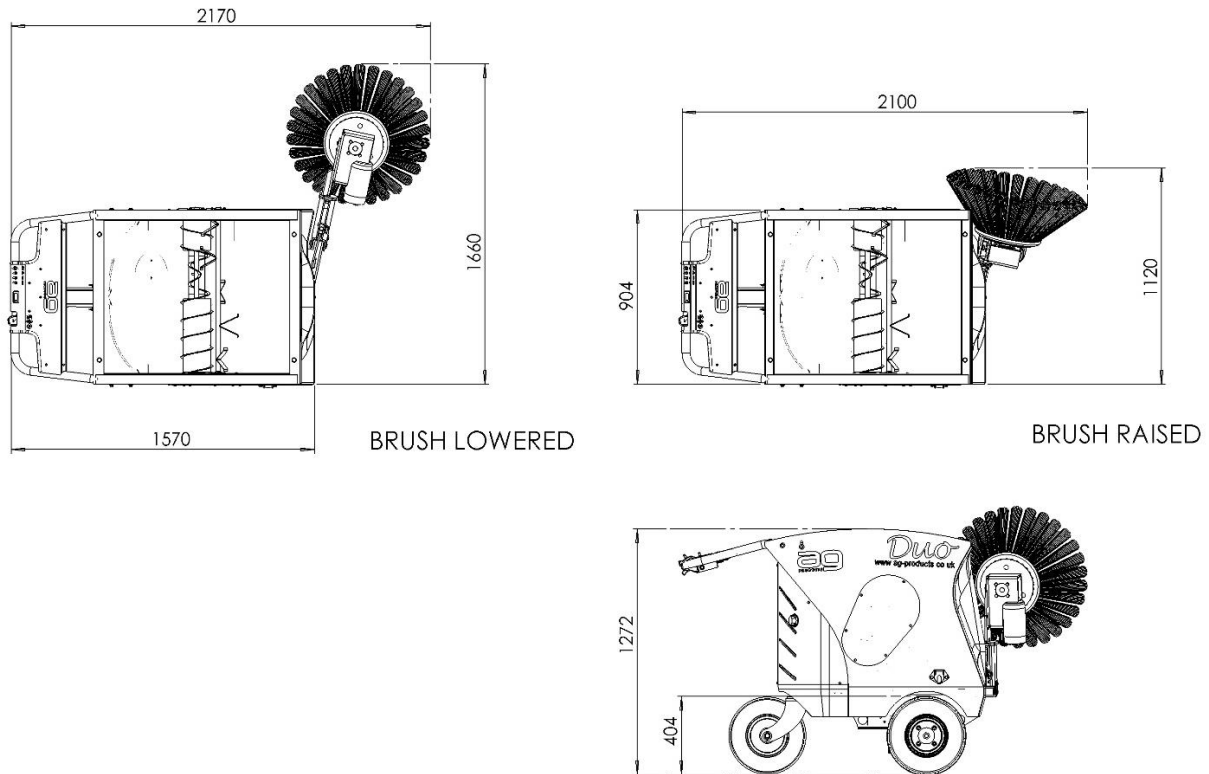

3.2 TECHNICAL SPECIFICATIONS

Unladen weight as standard	310 kg
Unladen weight with optional scraper	330 kg
Hopper capacity	350 litres
Battery	LiFePO4, 36v, 50Ah
Battery life per charge (approximate)	1000 cubicles depending on conditions
Battery weight	23.5 kg
Discharge method	Conveyor Belt
Discharge height	0.45m
Maximum discharge rate	215 litres per minute
Discharge distance (approximate)	1 m
Tyre pressure – driven wheels	1.9 bar (28 psi)
Tyre pressure – jockey wheel	2.9 bar (42 psi)

3.3 AIRBORNE NOISE EMISSIONS

Airborne noise emissions were measured at the operator's position, at a height of 1.6m from the floor within an open-ended shed. Background noise was measured at 36 dB.

With the AG Duo set to maximum conveyor speed and maximum auger speed and all other functions activated, a maximum sound pressure level of 71 dB was measured.

As a general rule, the greater the discharge rate, the higher the noise level.



Operators should be aware of the local regulations concerning noise and take the necessary steps to minimise the effects.

3.4 MACHINE IDENTIFICATION

The model and serial number of the dispenser are stamped on a plate located on the hopper rim at the rear of the machine.

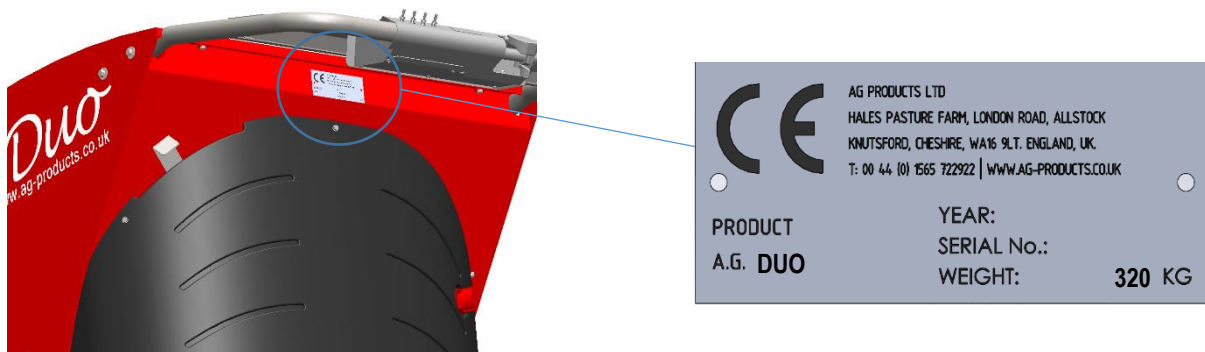

4 OPERATION AND SETTINGS

4.1 CHARGING THE AG DUO PRIOR TO USE



Please read the charger operating manual.

It is important that the machine is only charged with the charger supplied with the machine. Please read the Operating Manual supplied with the charger before use.

A copy of the Charger Operating Manual is also included in Section 9 of this manual.



Before charging, isolate the AG Duo (see Section 1.2.5)

To charge the AG Duo, plug the charger into the charger port, connect the charger to a mains supply and switch it on. Charge the AG Duo in a clean, dry space.

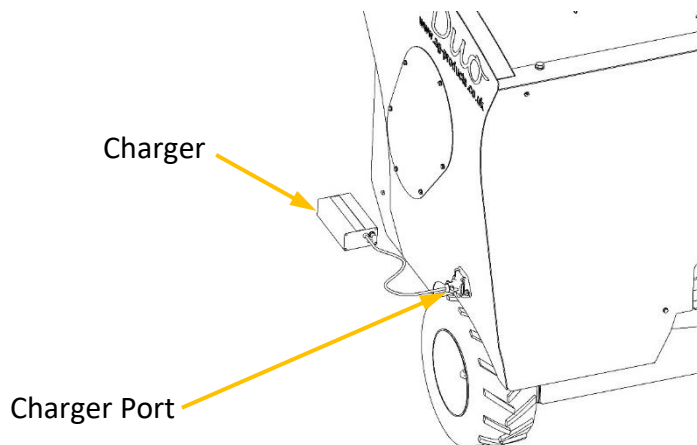

The battery level indicator will show the level of charge.

When the machine is fully charged the screen on the AG Duo will read 100%. The machine is now ready for use.

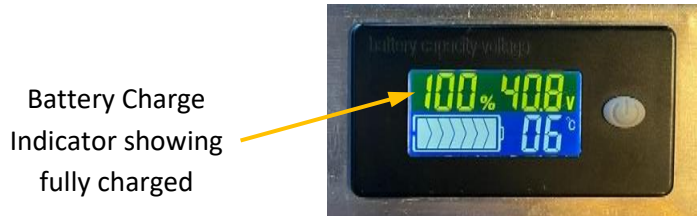

IMPORTANT NOTES:

- The battery should be fully charged before the first and every subsequent use.
- It will reduce the life of the battery if it is regularly allowed to fully discharge.
- If the AG Duo is unlikely to be used for a period exceeding 2 months, the battery should be put on charge every 2 months for 1 hour.

4.2 CONTROLS

Controls for the operation of the AG Duo are positioned on the handlebar panel.

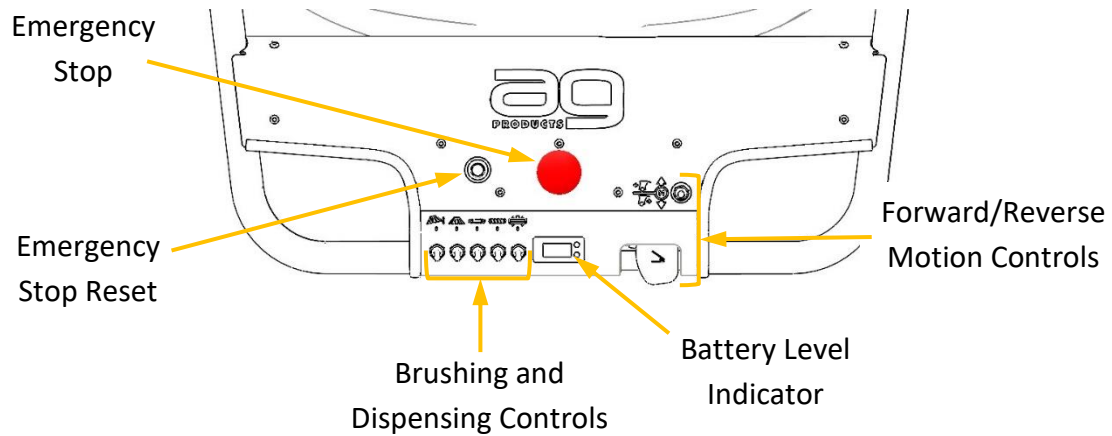

The emergency stop is provided to halt all the elements of the AG Duo should the occasion arise.

The emergency stop should not be used to stop the AG Duo in normal operation.

To restart the AG Duo after the application of the emergency stop, the stop button should be lifted and the reset button pressed.

Note also that the reset button must be pressed whenever the AG Duo is powered up.

The brushing and dispensing functions of the AG Duo are independently operated by a series of switches on the left of the handlebar panel. They are arranged in the order in which they are normally used, i.e. on starting:

- Lower brush.
- Turn brush on.
- Turn conveyor on.
- Turn auger on.

On completion of a line of cubicles, the normal sequence for stopping these functions is:

- Auger off.
- Conveyor off.
- Brush off.
- Raise brush.

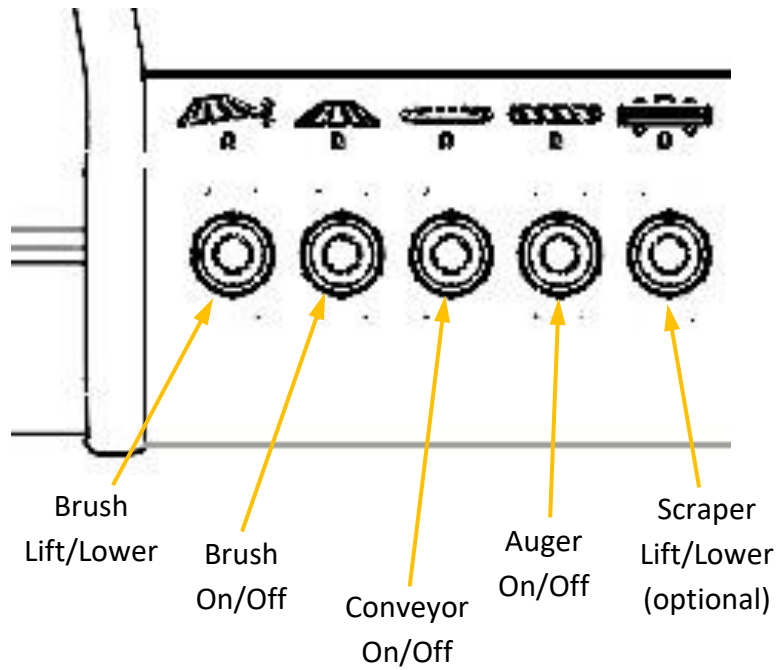

The direction and speed of the AG Duo are controlled by a forward/reverse switch and throttle lever on the right of the handlebar panel.

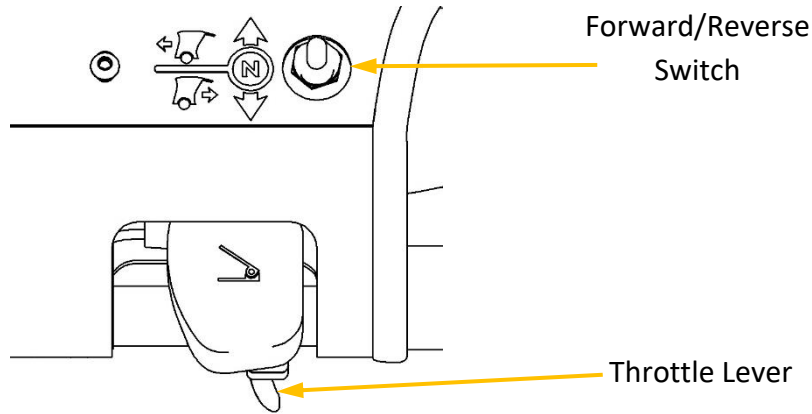

The forward/reverse switch engages drive to the axle. It has three positions: forward, neutral and reverse. Once engaged, the speed of the AG Duo is controlled by the throttle lever.



When not in use, always leave the forward/reverse switch in its neutral position, isolate the machine and apply the parking brake – See Sections 1.2.5 and 1.2.6.

If left on a slope, the AG Duo may creep slowly downhill. Be sure to apply the parking brake.

Until confident of the use of all of the controls, it is advisable to complete several practice runs to get used to the switches and speed of the machine.

1. Ensure the AG Duo is fully charged.
2. Ensure there are no bystanders around the AG Duo.
3. Ensure the hopper is empty.
4. Check all operations and familiarise yourself with the switch positions, actions and forward and reverse drive speeds.

If operating the AG Duo on a downward slope, it is best to leave the forward/reverse switch in the forward position and regulate the speed with the throttle lever. Do not be tempted to engage reverse under these circumstances.

4.3 ADJUSTMENTS

The **discharge rate** is governed by:

1. The size of the metering shutter opening.
2. The speed of the auger and agitator.
3. The speed of the conveyor.

The **spread pattern** is governed by:

1. The forward speed of the AG Duo
2. The speed of the conveyor.
3. The amount of product falling onto the conveyor belt (metering shutter opening and auger & agitator speed).

4.3.1 METERING SHUTTER

The metering shutter should be adjusted to provide a suitable opening at the bottom of the hopper to obtain the desired bedding flow rate. The size of the opening will determine the rate of flow that the bedding product flows onto the conveyor belt and will depend on the bedding product and your needs. The ideal opening will be found through trials.

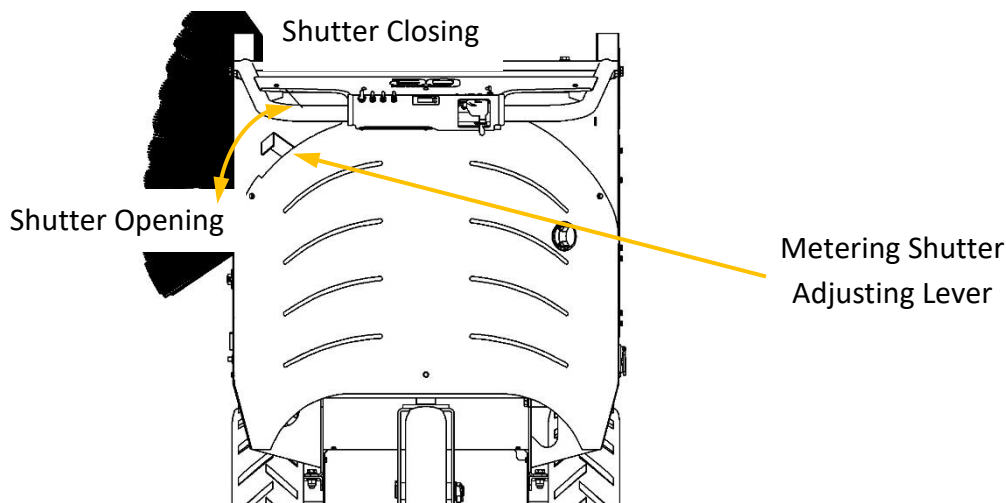

Moving the adjusting lever to the right will reduce the opening size, thus reducing product flow.

Moving the adjusting lever to the left will increase the opening size, thus increasing product flow.

4.3.2 CONVEYOR AND AUGER SPEEDS

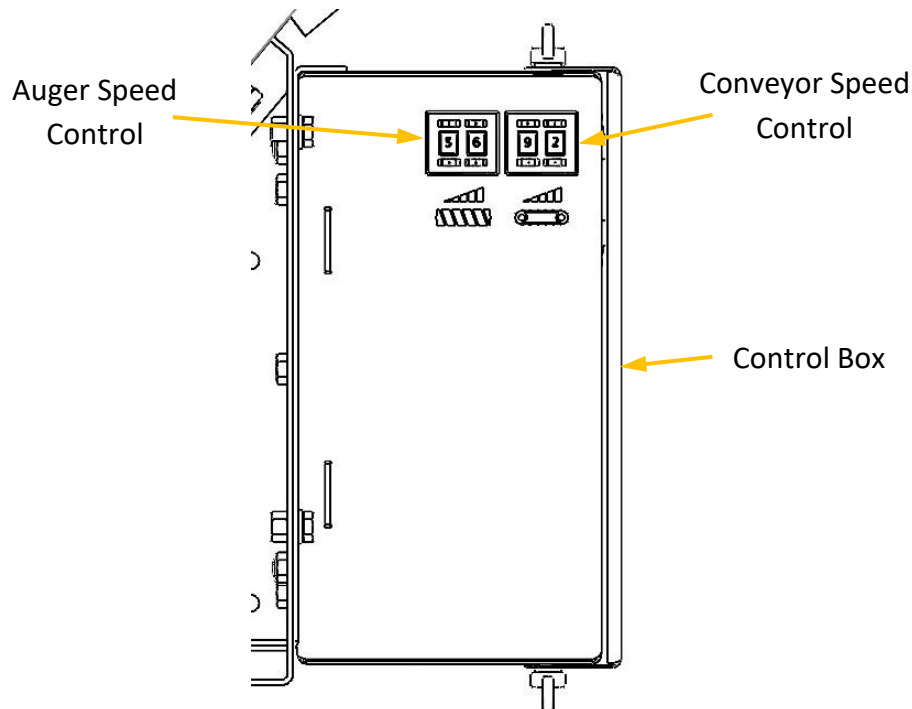

The conveyor and auger speed controls are located behind the rear moulded black cover, on the side of the control box.

The black cover may be left off until you are satisfied with the speed and volume of bedding being dispensed.



**Take extra care when using the AG Duo with any of the covers removed.
Danger of moving parts.**



All covers must be fitted before full operation.

The speed control for the conveyor alters the speed of the conveyor belt. A faster speed increases the distance that the product is dispensed. A slower speed will reduce the distance.

The speed control for the auger alters the speed of the auger and the agitator. This setting ensures an even flow of product onto the conveyor.

If the auger is set too fast, the product will tend to spill out of the hopper when full and can result in a stoppage due to an overload (see Section 4.4.1).

If the auger is set too slow, the product will not flow from the hopper onto the conveyor consistently. This results in an uneven spread.

The speed controls are adjusted by pressing the + or – buttons. The buttons on the right of each control result in a small increase or decrease in speed, the buttons to the left give a larger increase or decrease. The maximum speed is with the control set to 9.9. A setting less than 1.5 is unlikely to be of practical use.

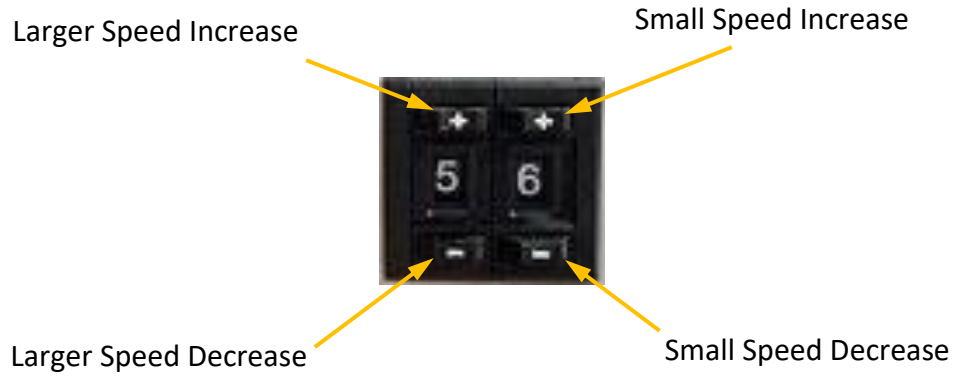

4.3.3 SWEEPING BRUSH HEIGHT

The sweeping brush is mounted on a floating arm that allows the brush to self-compensate for unevenness in the floor and for the brush to float over joints in mats without lifting them.

To cater for differences in kerb height, there is a 3-position height setting to suit a wide variety of heights. Due to the floating nature of the brush arm, this is not a critical adjustment. It also adds the ability to adjust the pressure onto the brush, useful for cleaning heavily soiled cubicles or cubicles that have not been mechanically swept before.

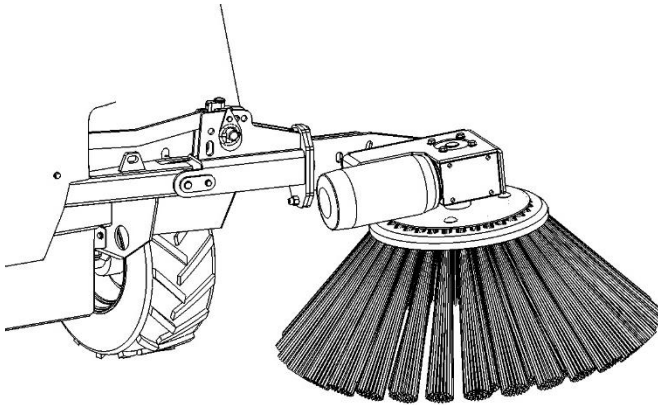

Brush at Lowest Setting

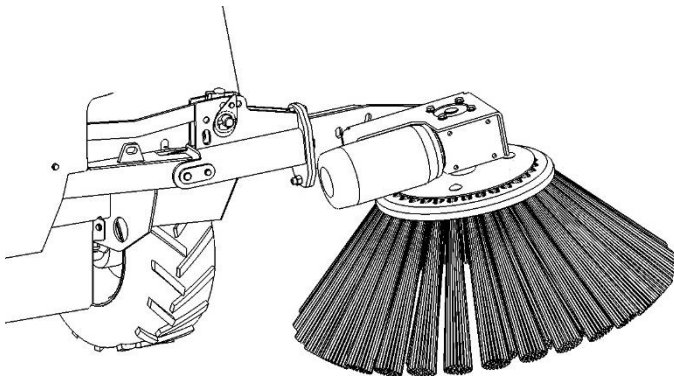

Brush at Middle Setting

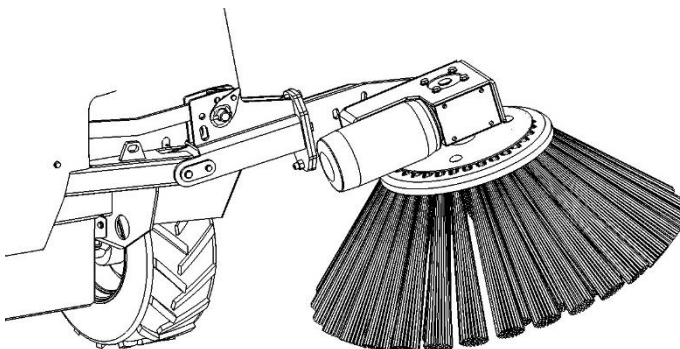

Brush at Highest Setting

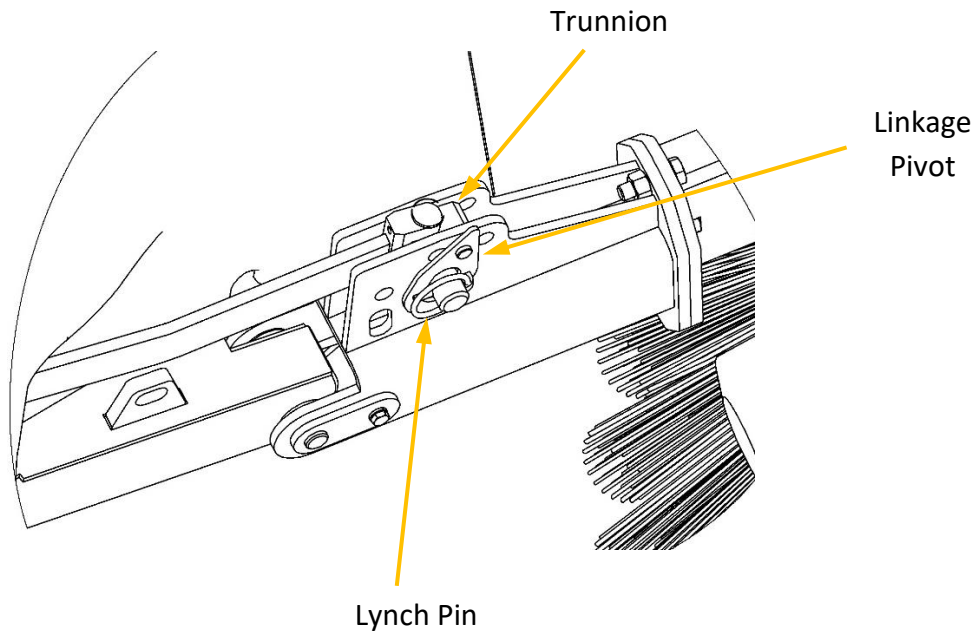

To adjust the brush height:

- Fully lower the brush arm
- Support the weight of the brush arm.
- Release the lynchpin and pull the linkage pivot out.
- Adjust the brush arm to the desired position.
- Locate the linkage pivot and push back in so that it re-engages with the trunnion.
- Re-fit the lynchpin.

4.3.4 SWEEPING BRUSH ANGLE

To ensure that the brush sweeps old bedding away from the cubicles, only the front of the brush should be in contact with the cubicle surface.

This can be achieved by adjusting the brush head using two adjustments. This adjustment may be necessary if the height setting has been changed.

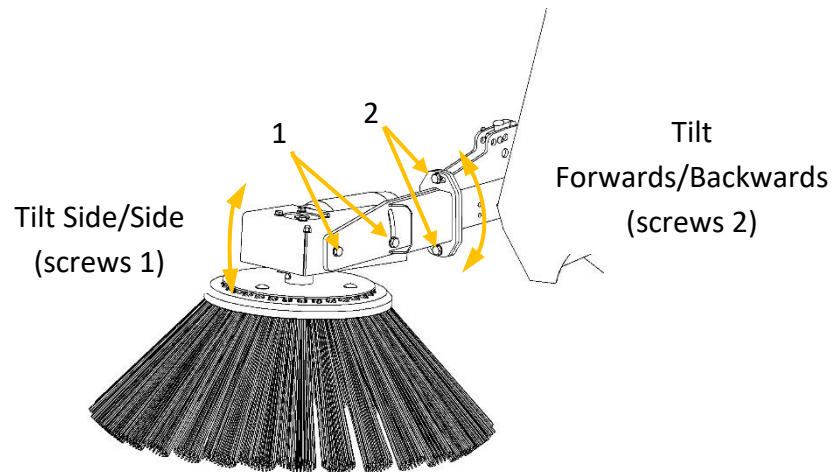

- Adjustment using the screws at position 1 tilts the brush from side to side. The recommended position is with the brush set approximately parallel to the cubicle surface.
- Adjustment using the screws at position 2 will tilt the brush head forwards and backwards. The recommended position is with the brush tilted slightly forwards so that only the front of the brush contacts the cubicle surface.

4.4 FAULT CONDITIONS & RECOVERY

4.4.1 OVERLOAD RESET

If the AG Duo has become blocked, the brush has become jammed or the machine has been driven into an obstruction, an electrical overload will likely occur. The overloaded mechanism will automatically stop. Once the cause of the overload has been identified and removed (see 4.4.2 below), the procedure for resetting depends on the mechanism that has stalled, as follows:

Device	Re-Set Procedure
Brush Lift/Lower	Briefly operate the switch to the opposite direction from when it stalled.
Brush Rotation	Briefly switch the brush off.
Conveyor	Briefly switch the conveyor off.
Auger	Briefly switch the auger off.
Axle Drive	Switch to the opposite direction position and gently operate the throttle until the AG Duo moves slightly.
Scraper Lift/Lower	Briefly operate the switch to the opposite direction from when it stalled.

4.4.2 BLOCKAGE REMOVAL



Always make sure the AG Duo is stopped on flat ground, is then isolated (see Section 1.2.5), and has the parking brake applied (see Section 1.2.6).



Wear appropriate PPE (Personal Protective Equipment) when carrying out all maintenance or service work.

If, during the dispensing of the bedding product, the auger or conveyor stalls, follow the procedure below:

1. Bring the AG Duo to a stop and isolate the machine, ensuring that the isolator switch is removed (see Section 1.2.5).
2. Apply the parking brake (see Section 1.2.6).
3. Look into the hopper and remove any foreign objects.
4. Look along the conveyor bed and remove any foreign objects.
5. The use of a pry bar is recommended to remove any blockage to minimise the potential for entrapment, cuts and bruises.
6. Once any foreign objects have been removed turn on the machine and test.
7. If the AG Duo is still blocked, stop and isolate the machine and contact your local dealer or Garnett Farms Engineering Ltd for further advice.

4.4.3 CIRCUIT BREAKER

An extreme overload may cause the circuit breaker to trip. If this occurs, all power to all the mechanisms will be lost.



IMPORTANT

Isolate the AG Duo before attempting to access the circuit breaker.

See Section 1.2.5.

Also, ensure all brushing and dispensing controls are in their off positions, the forward/reverse switch is in the neutral position, and the parking brake is applied.

The circuit breaker is located behind the rear moulded black cover and inside the control box. Access is gained by removing the six Phillip screws.

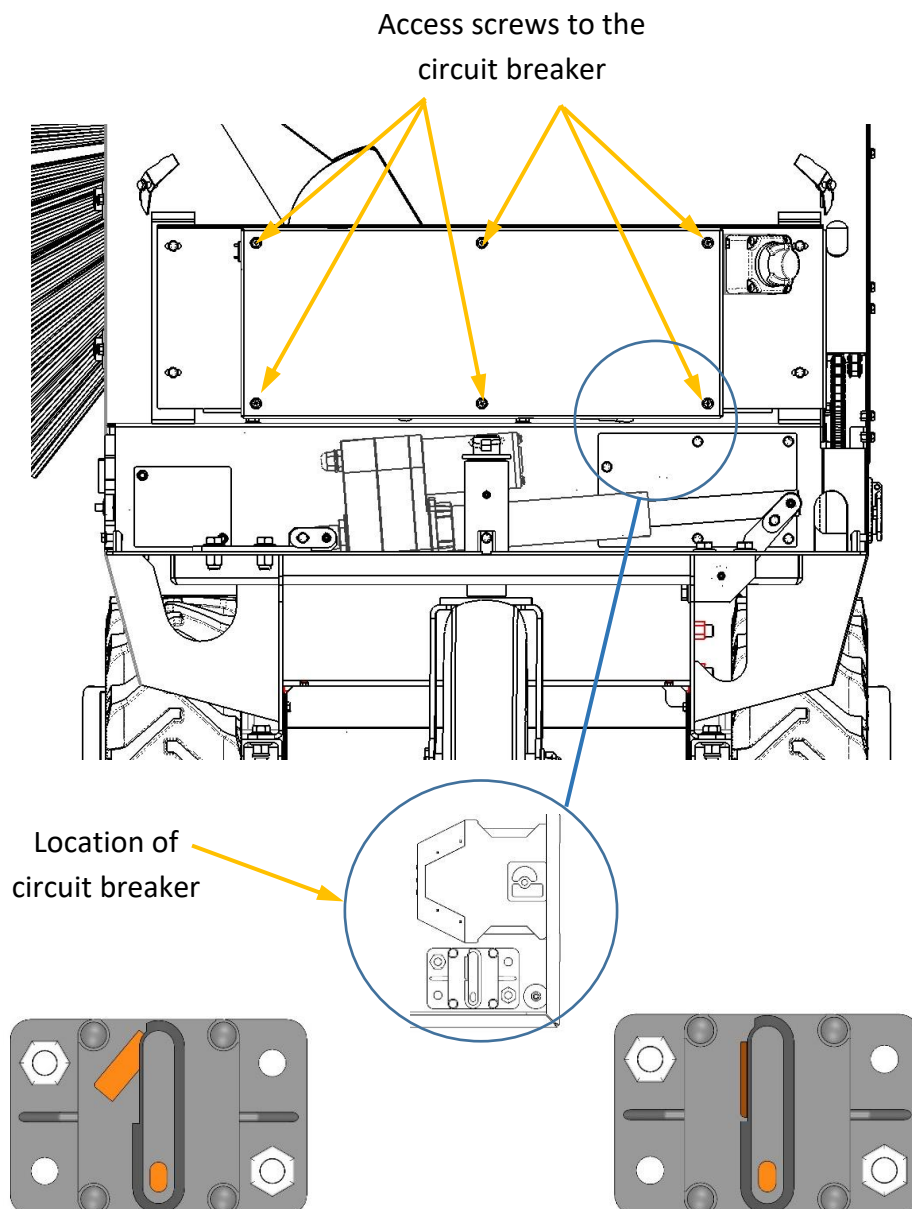

Circuit breaker shown
in open (OFF) position.

Circuit breaker shown
in closed (ON) position

If the circuit breaker has tripped, it can be reset by pushing the brown lever back into position as shown in the following picture.

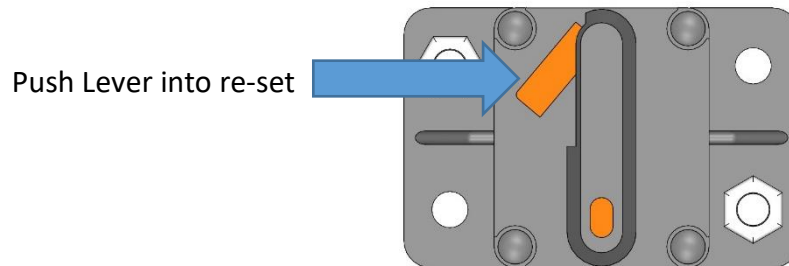

Double check that all brushing and dispensing controls are in their off positions, and the forward/reverse switch is in the neutral position before turning the isolator to the on position.

If the breaker trips out again after resetting, isolate the machine immediately and contact your local dealer or Garnett Farms Engineering Ltd.

4.4.4 EMERGENCY STOP

To restart the AG Duo after the application of the emergency stop, the stop button should be lifted and the reset button pressed.

The reset button must also be pressed whenever the AG Duo is powered up.

5 MAINTENANCE



During maintenance procedures, the AG Duo must be stopped and secured on flat ground, the isolator turned off with the isolator switch removed, and the parking brake applied. See Sections 1.2.5, 1.2.6 and 1.2.10.



Wear appropriate PPE (Personal Protective Equipment) when carrying out all maintenance or service work.

5.1 SERVICE SCHEDULE

The AG Dispenser is designed for optimum performance with minimum requirement for maintenance. The following service schedule should be observed:

Every 50 hours of operation:

- Grease the points shown in Section 5.2.

Every 3 months:

- Check tyre pressures (see Section 3.2) & effectiveness of the parking brake.
- Check E-Stop operation.

Every 6 months:

- Check the condition of the hopper.
- Replace missing or illegible safety stickers.
- Check the security of the auger.
- Check auger flights for excessive wear or damage.
- Check auger bearings for excessive movement.
- Check auger chain drive security and tension.
- Check the security of the agitator.
- Check agitator bearings for excessive movement.
- Check agitator chain drive security and tension.
- Check the condition of the conveyor belt.
- Clean out any build-up of bedding product between the inside of the belt and the rollers.
- Check conveyor belt alignment & tension.
- Check the condition and adjustment of the conveyor side skirts.
- Check conveyor rollers are free-running and secure.
- Check conveyor end roller bearings for excessive movement.
- Check the security of the conveyor motor.

Every 12 months:

- Service by your local dealer or AG Products.

5.1.1 IN STORAGE

If the AG Duo is unlikely to be used for a period exceeding 2 months, the battery should be put on charge every 2 months for 1 hour. It will reduce the life of the battery if it is regularly allowed to fully discharge.

The battery should be fully charged again before the next use.

5.2 GREASING POINTS

Four greasing points are found behind the rear moulded black cover.

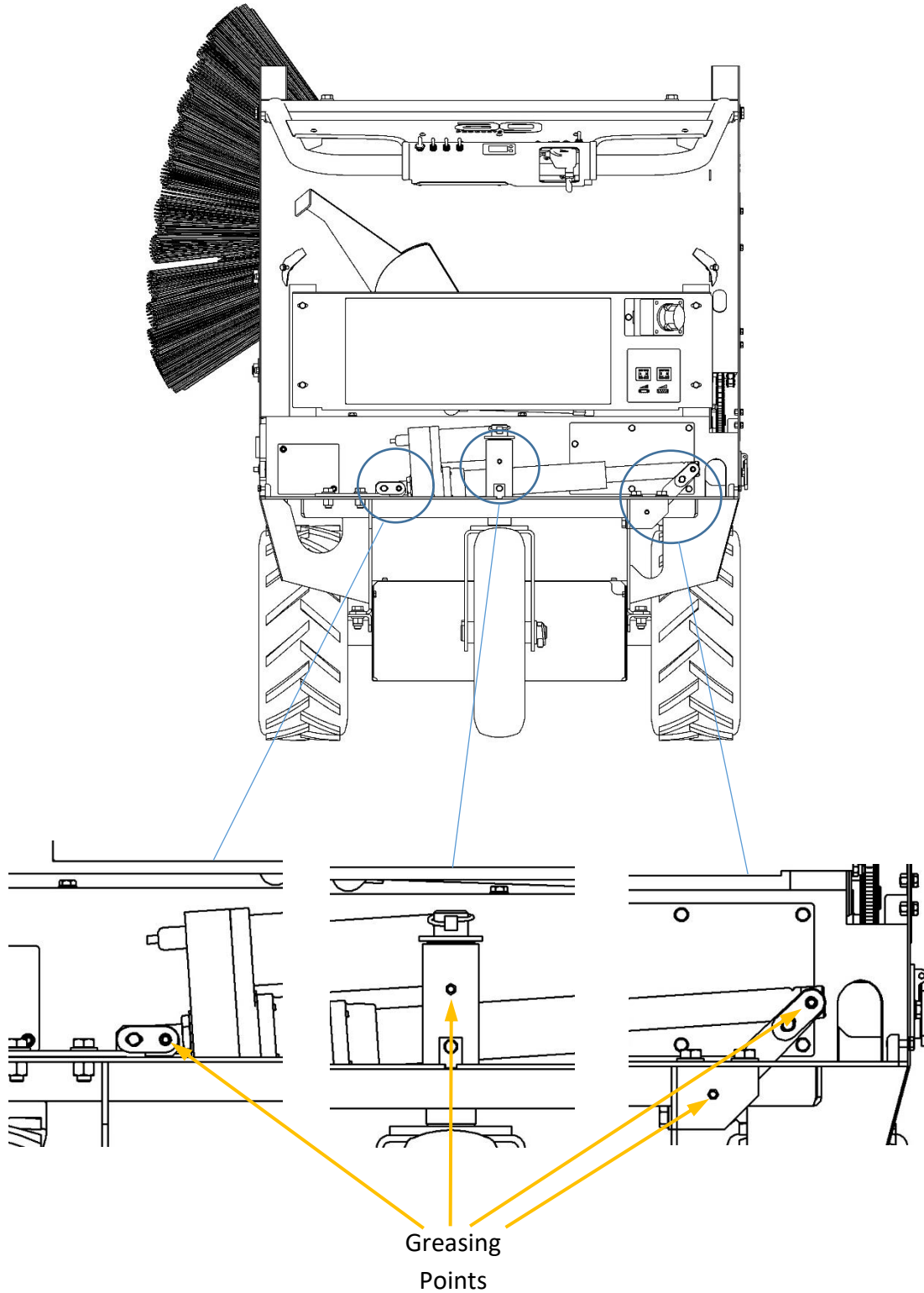

One greasing point is found behind the front moulded black cover.

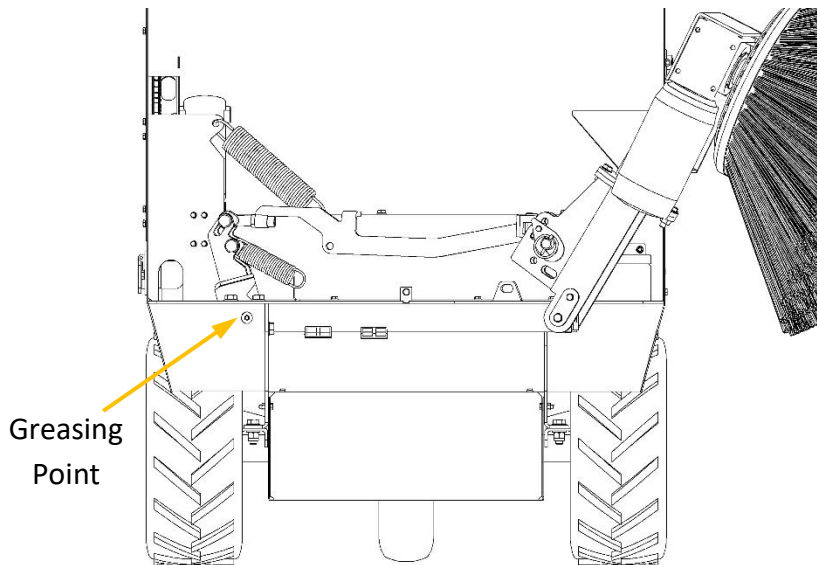

And one greasing point is on the main pivot of the brush arm, accessible with the brush arm raised.

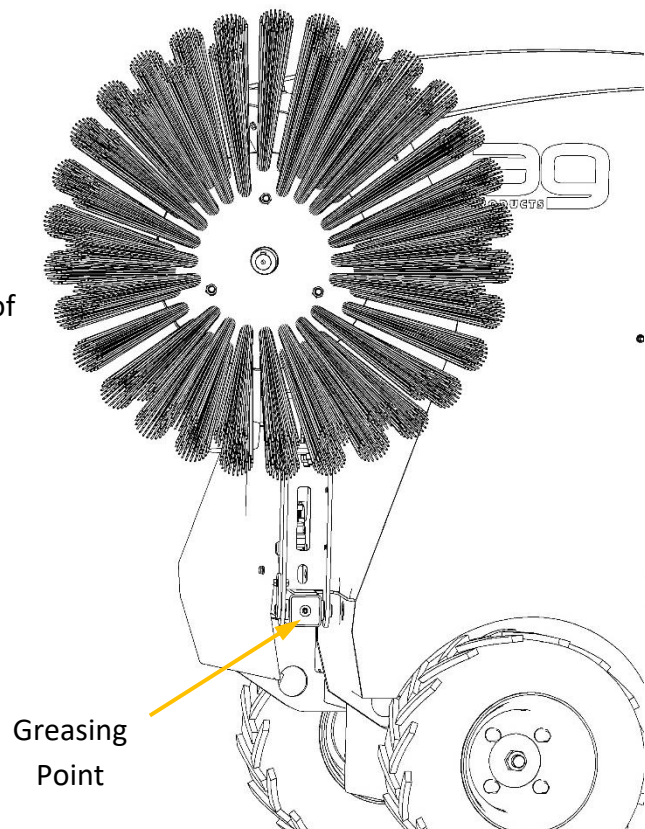

There are 6 greasing points on the scraper if fitted.

Four are located on the support arms:

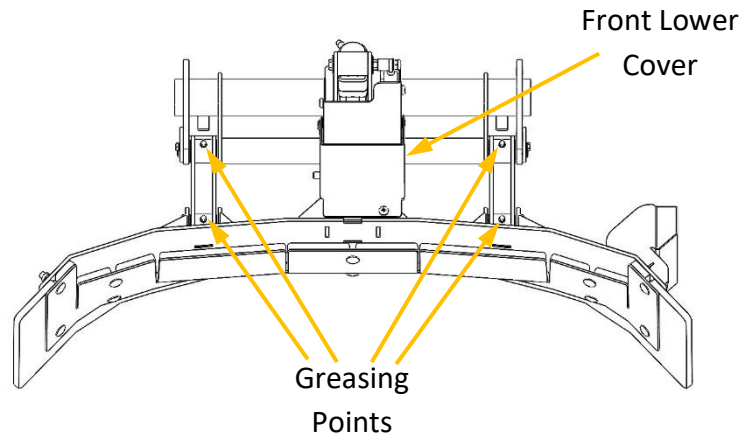

Removal of the front lower cover reveals another greasing point:

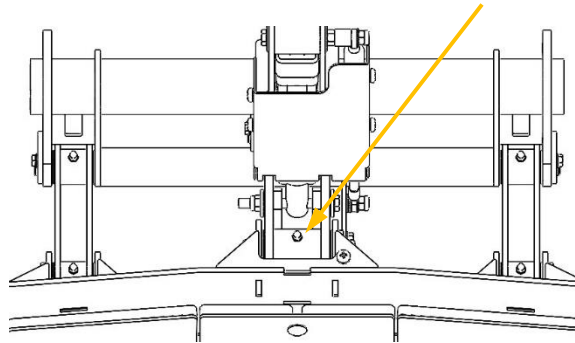

And the final greasing point is accessed from the rear of the scraper:

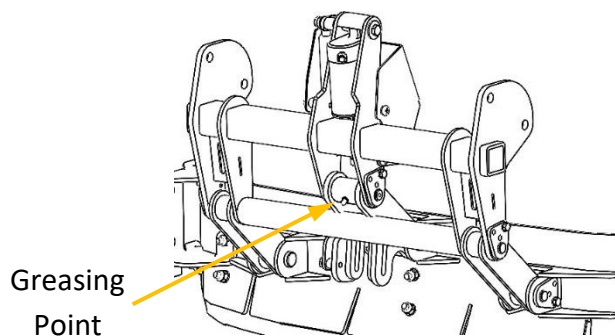

5.3 CONVEYOR BELT ALIGNMENT AND ADJUSTMENT

The conveyor belt must run centrally on the conveyor end rollers. If the conveyor belt is off-centre, it may cause unnecessary drag, slow the belt down and compromise performance.

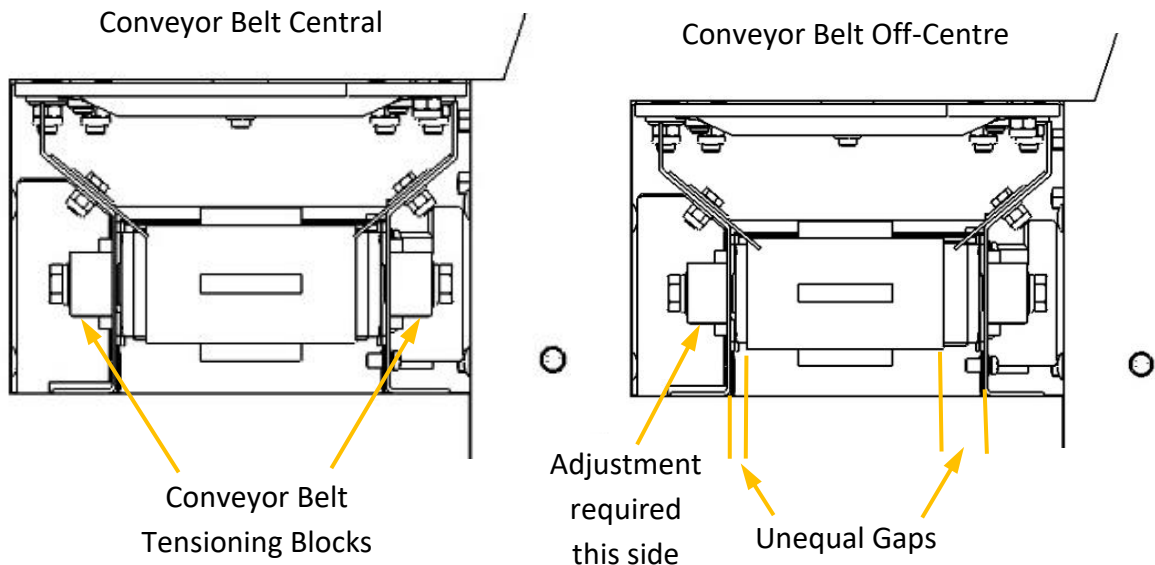

The running position of the conveyor belt is adjusted by slightly increasing the tension of the side of the belt that is running too close to the conveyor side. In the case shown above, it is the tension on the left side that should be increased.

Access for tensioning is via panels on each side of the conveyor tunnel. The front or rear moulded black covers will have to be removed as necessary.

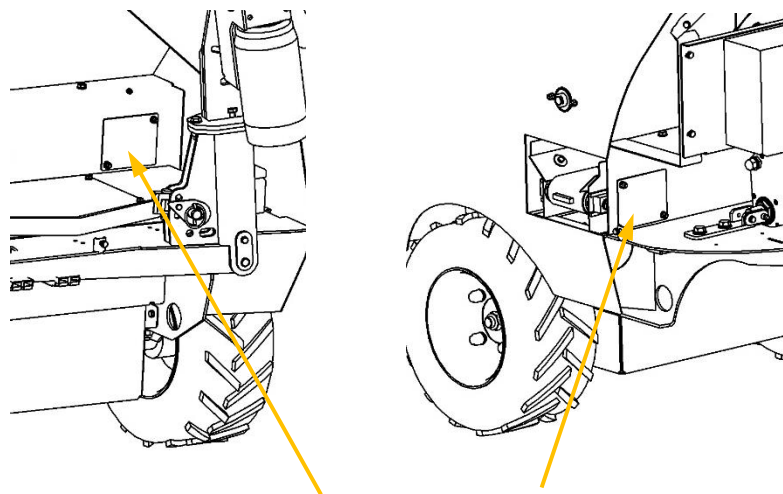

Conveyor Belt Tensioning Access Panels

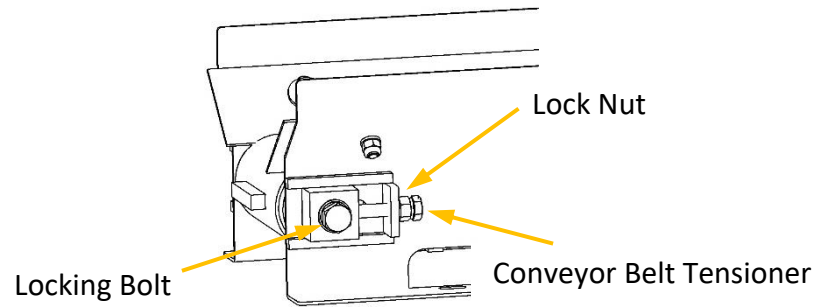

Slacken the locking bolt and the lock nut and use the belt tensioner to increase the belt tension. The belt can be turned by hand, in the correct direction of travel, after each adjustment to gauge the effect. Small adjustments can make a difference and it is recommended that the adjustment is made one flat at a time.

Tighten the lock nut and locking bolt.

As a final alignment check, the conveyor may be run under power.



Take extra care when using the AG Duo with any of the covers removed.



Danger of moving parts.

All covers and access panels must be fitted before full operation.

If it is suspected that the conveyor belt is running slow, this can indicate that the belt is slipping due to insufficient tension. In this case, the tension should be increased on both sides. Always check that the belt is running centrally after any tension adjustments.

Be cautious not to overtighten the conveyor belt as this may cause premature wear on other moving parts.

If in doubt, contact your local dealer or Garnett Farms Engineering Ltd. for advice.

5.4 CONVEYOR DRIVE BELT TENSION

If the conveyor drive is intermittent and noisy, this may indicate that the drive belt may require adjustment. To do this, the conveyor must be removed from the AG Duo, as follows:

- Remove the conveyor motor access panel and disconnect the motor supply wires.

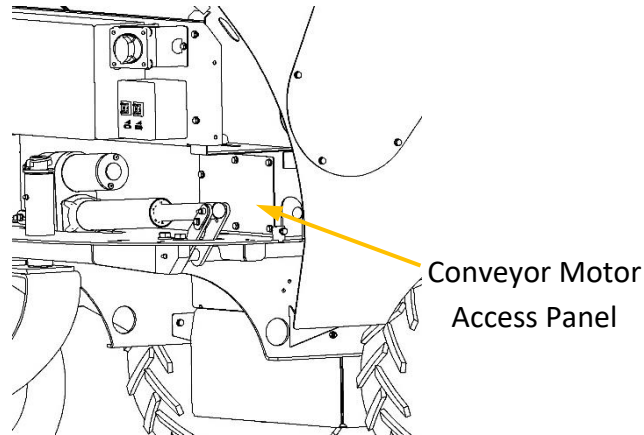

- Release the 4 screws securing the conveyor. These are best accessed from the underside of the AG Duo. Cut-outs are provided in the conveyor sides for access to the nuts.



Take extra care when working under the AG Duo. Ensure the AG Duo is secure.

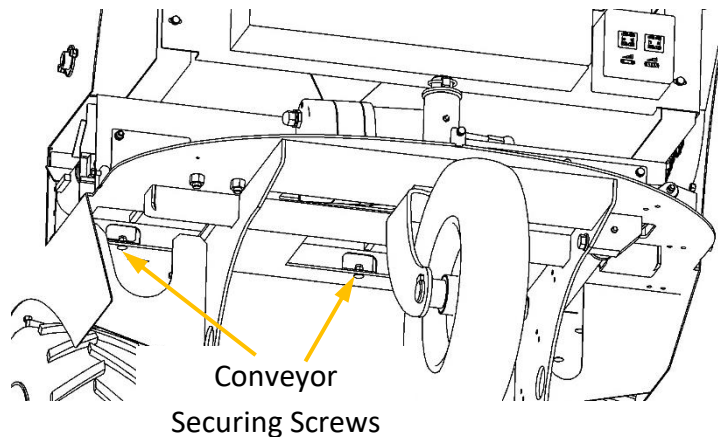

- The complete conveyor can now be slid out from the tunnel.

Once the conveyor is removed, the drive belt cover can be removed and the belt tension adjusted by slackening the motor screws.

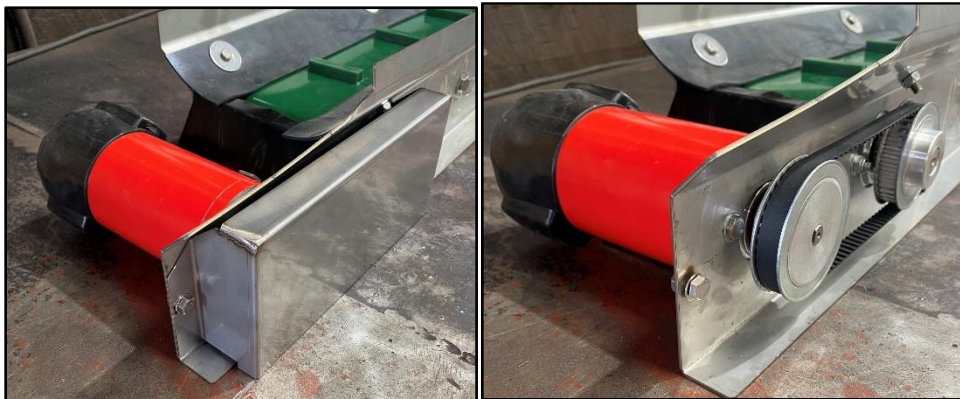
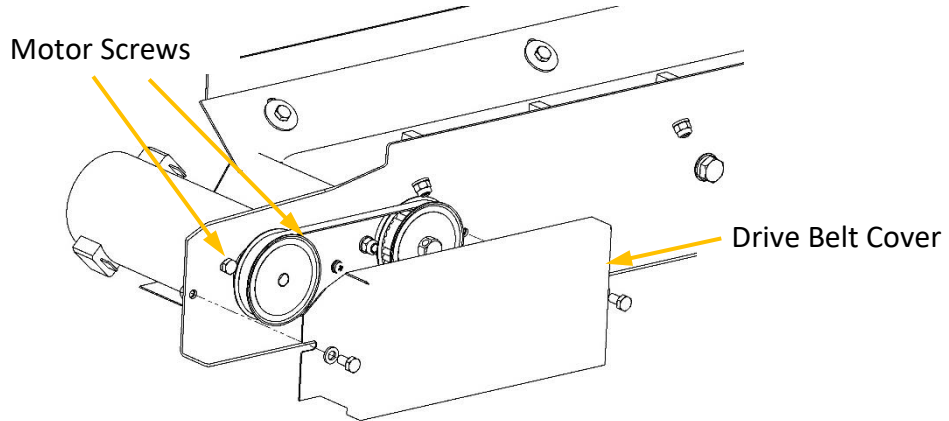

5.5 AGITATOR AND AUGER CHAIN ADJUSTMENT

The AG Duo has an agitator and auger fitted as standard. The auger, below the agitator, is designed to increase the flow rate to the conveyor. The agitator is driven by the auger below it and helps prevent material bridging inside the hopper.

The auger is driven via chain and sprocket from the agitator motor and gearbox, which is fixed to the chassis towards the front of the AG Duo. +36 V from the electrical enclosure powers the agitator motor.

The Agitator Chain is located behind the side cover panel.

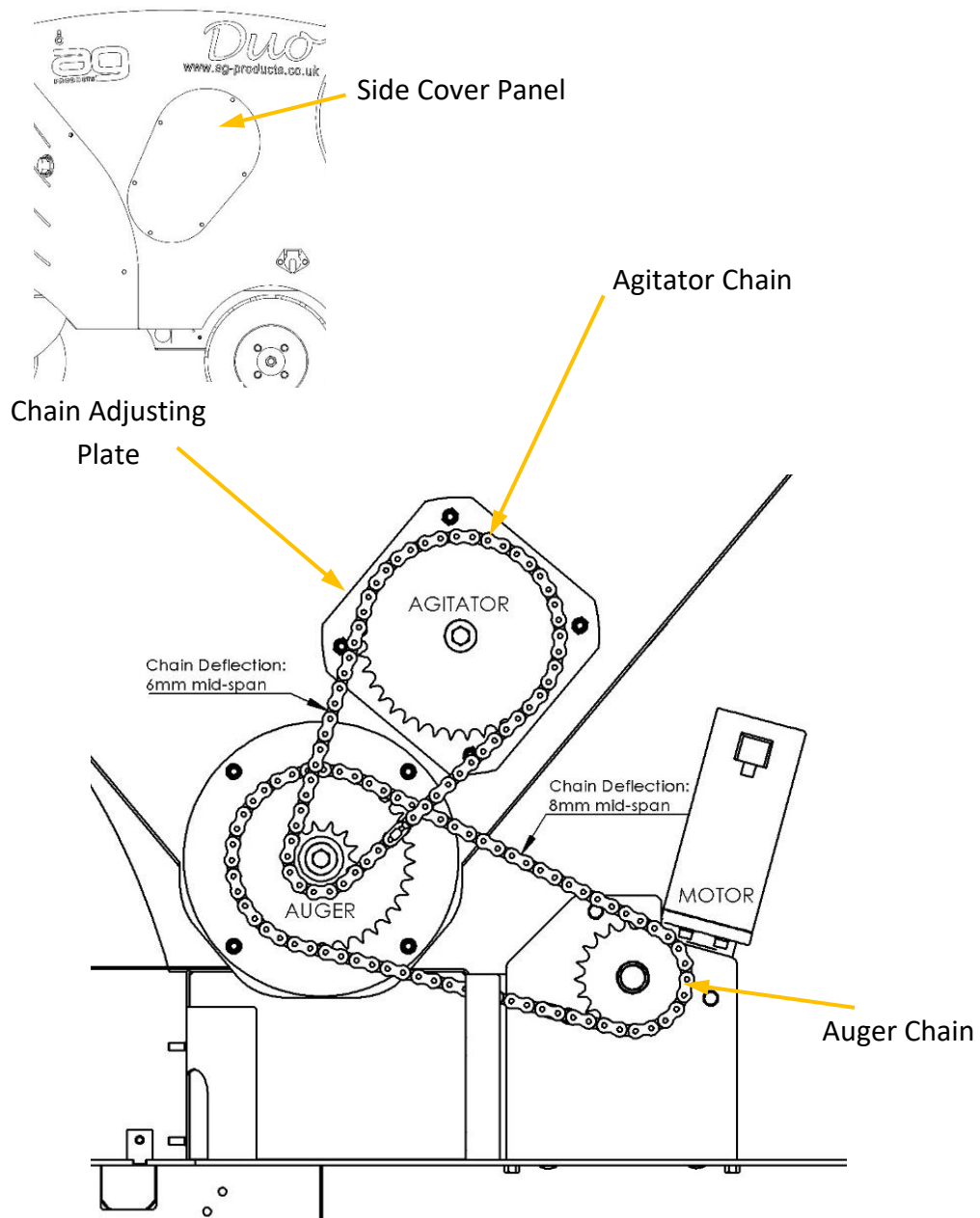

The agitator chain can be tensioned by loosening the four nuts at the corners of the chain adjusting the plate and adjusting the position of the plate to achieve the correct chain mid-span deflection as shown in the above diagram. Re-tighten the four nuts.

The auger chain can be tensioned by loosening the two nuts that secure the auger motor bracket and adjusting the position of the bracket to achieve the correct chain mid-span deflection as defined in the above diagram. To access the auger motor, remove the front moulded black cover.

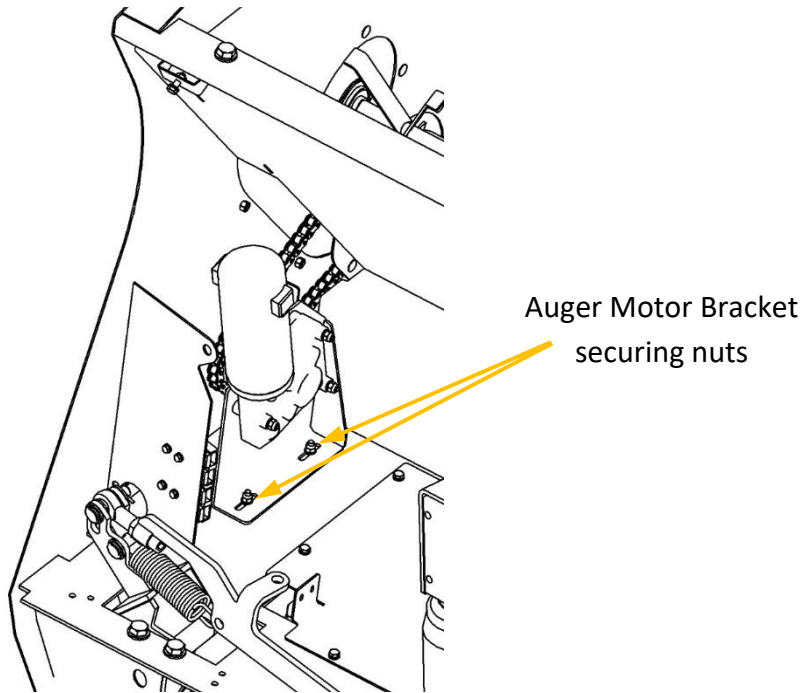

5.6 SCRAPER BLADE ADJUSTMENT

Some vertical adjustment of the Scraper Blade is available to compensate for blade wear.

Slacken the 10 nuts as indicated on the rear of the scraper to adjust.

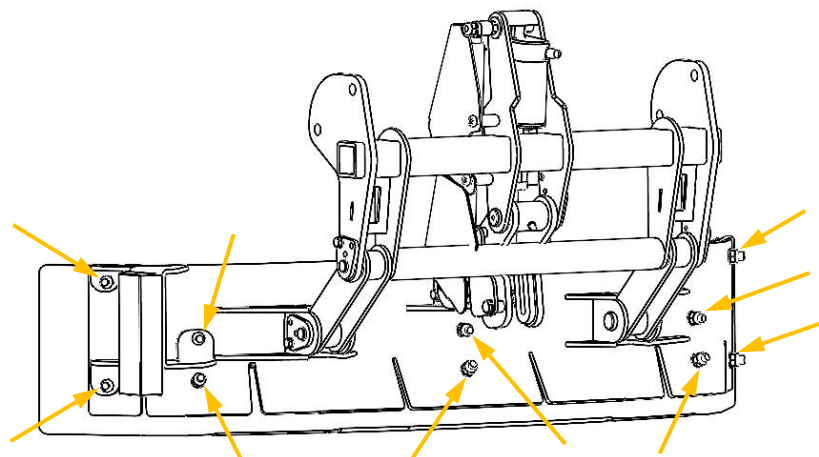

6 REPLACEMENT OF SERVICE ITEMS



During service procedures, the AG Duo must be stopped and secured on flat ground, the isolator turned off and the isolator switch removed. See Sections 1.2.5 and 1.2.9.



Wear appropriate PPE (Personal Protective Equipment) when carrying out all maintenance or service work.

6.1 BRUSH REPLACEMENT

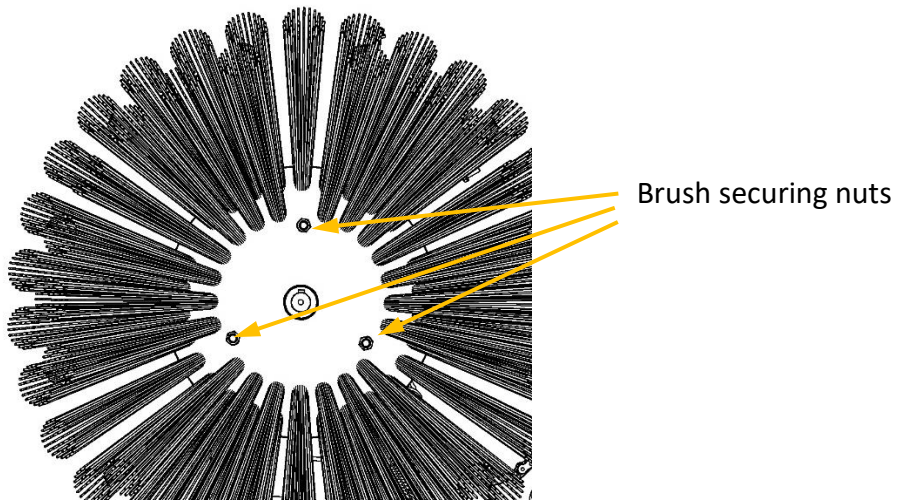

The brush is secured with three M10 nuts. Removing these nuts allows the brush to be removed and replaced.

Use only genuine AG parts when replacing the brush. Other brushes may not be compatible with the brush drive system and can damage other parts of the AG Duo.

6.2 CONVEYOR BELT REPLACEMENT

- Remove the conveyor from the AG Duo. Refer to Section 5.4.
- Slacken the conveyor belt. Refer to Section 5.3.
- Remove the conveyor side by removing the screws as indicated.

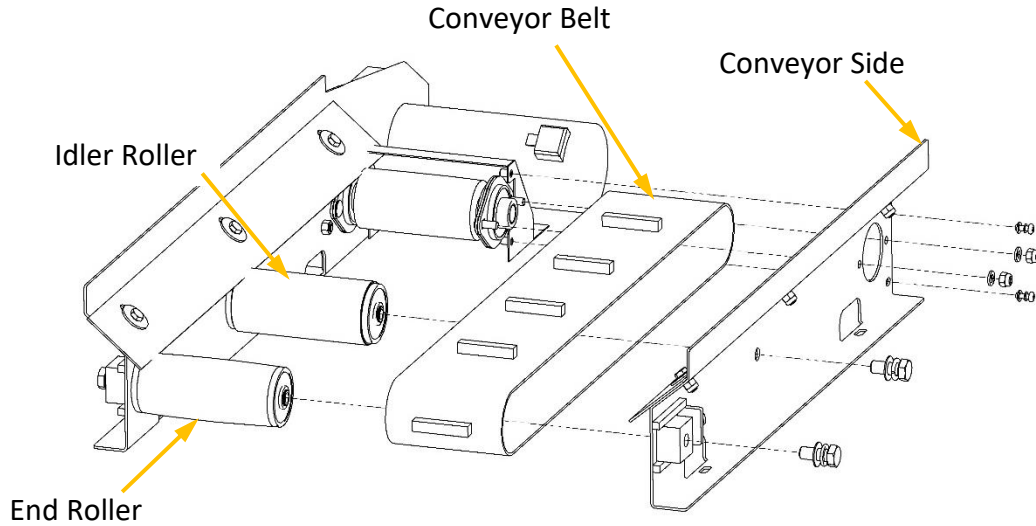

The conveyor can now be slid from the rollers for replacement. See Section 5.3 for belt alignment and adjustment.

6.3 CONVEYOR ROLLER REPLACEMENT

Follow the procedure above.

NOTE: The end roller and the idler roller are **NOT** the same. The end roller is profiled and it will not be possible to align the belt properly if the incorrect rollers are fitted.

6.4 CONVEYOR SIDE SKIRT REPLACEMENT

- Remove the conveyor from the AG Duo. Refer to Section 5.4.
- Replace the conveyor side skirts as necessary and re-fit as shown below.

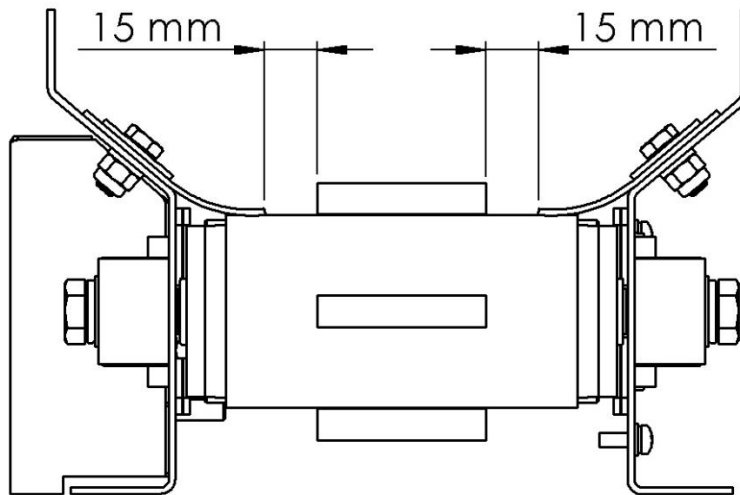

The conveyor side skirts are fixed to the conveyor sides. It is important to adjust the side skirts as shown above to minimise product escaping to the inside of the conveyor belt. This can cause overload of the conveyor.

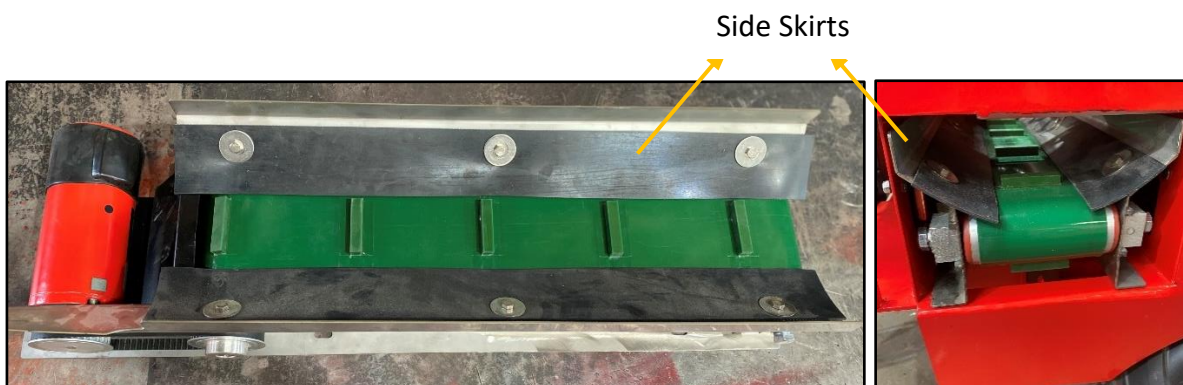

6.5 SCRAPER BLADE REPLACEMENT

- Remove the 10 nuts as indicated on the rear of the scraper.

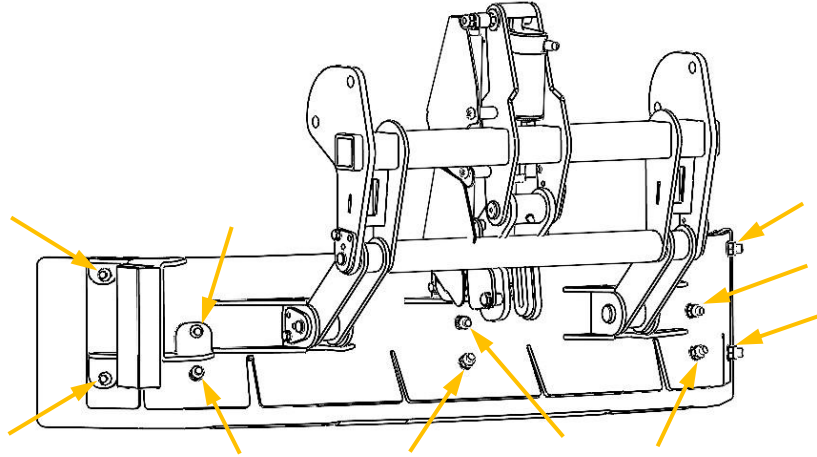

- The metal front plate and the scraper blade can then be removed.

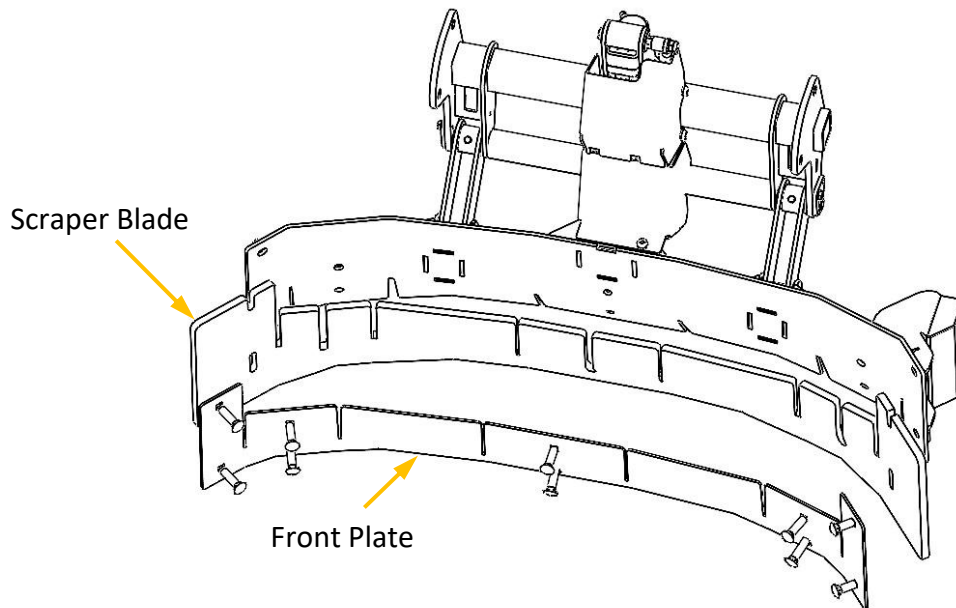

6.6 SKID BLOCK REPLACEMENT

The skid block is removed and replaced by releasing the 2 screws as indicated at the rear of the scraper.

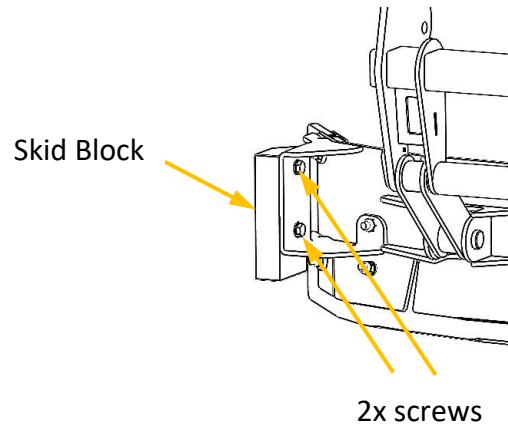

6.7 BATTERY REPLACEMENT



See Section 1.2.12 for safety precautions to be taken when changing or handling the battery.

The battery compartment is sited behind the front moulded black cover.



Remove the battery compartment cover which is held by 6 screws.

Disconnect the battery.

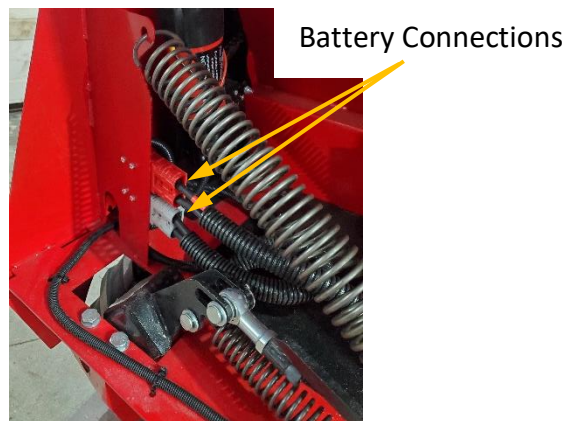

Insert the new battery and connect, plugging the red plug into the red socket and the grey plug into the grey socket.

Re-fit the battery compartment cover taking care not to trap any wires.

The used battery should be returned to Garnett Farms Engineering Ltd or an authorised distributor for refurbishment or disposal.

7 TROUBLESHOOTING

The problems, possible causes and remedies listed below are only a guide and guidance should be sought from your local dealer or Garnett Farms Engineering Ltd if you are unsure at any point.

Problem	Possible cause	Remedy
The machine has no power.	Isolator is turned off.	Turn the isolator on. (See Section 1.2.5)
	Battery is flat.	Charge the battery. (See Section 4.1)
	Reset button has not been pressed after power up.	Press Reset Button. (See Section 1.2.7)
	Circuit breaker has tripped.	Reset the circuit breaker. (See Section 4.4.3)
	Emergency stop button has been pressed.	Reset emergency stop. (See Section 1.2.7)
Parking brake not holding.	Tyre pressure low.	Inflate tyre. (See Section 3.2)
Insufficient bedding is being dispensed.	Gap in the metering shutter is too small.	Open the metering shutter to suit the bedding in use. (See Section 4.3.1)
	Auger is not running fast enough.	Increase the auger speed. (See Section 4.3.2)
	Conveyor is not running fast enough.	Increase the conveyor speed. (See Section 4.3.2)
Too much bedding is being dispensed.	Gap in the metering shutter is too big.	Close the metering shutter to suit the bedding in use. (See Section 4.3.1)
	Auger is running too fast.	Reduce the auger speed. (See Section 4.3.2)
	Conveyor is running too fast.	Reduce the conveyor speed. (See Section 4.3.2)

Problem	Possible cause	Remedy
No product being dispensed.	Blockage.	Check for and remove blockage. (See Section 4.4.2)
	Auger stopped due to overload.	Reset the auger. (See Section 4.4.1) If the problem persists, reduce the auger speed. (See Section 4.3.2)
	Conveyor stopped due to overload.	Reset the conveyor. (See Section 4.4.1) If the problem persists, reduce the conveyor speed. (See Section 4.3.2)
Blockages occurring.	Auger is running too fast.	Reduce the auger speed. (See Section 4.3.2)
	Gap in the metering shutter is too small.	Open the metering shutter to suit the bedding in use. (See Section 4.3.1)
Brush is lifting the mats.	Brush is set too low.	Adjust the brush height. (See Section 4.3.3)
Brush is ineffective.	Brush is set too high	Adjust the brush height (See Section 4.3.3)
	Brush is set at the incorrect angle.	Adjust the brush angle (See Section 4.3.4)
Brush stopped.	Overload.	Reset the brush. (See Section 4.4.1)
Brush lift/lower not working.	Overload.	Reset the brush arm. (See Section 4.4.1)
Axle not driving.	Overload.	Reset the axle. (See Section 4.4.1)
Scraper not lifting/lowering.	Overload.	Reset the scraper. (See Section 4.4.1)

8 SPARE PARTS IDENTIFICATION

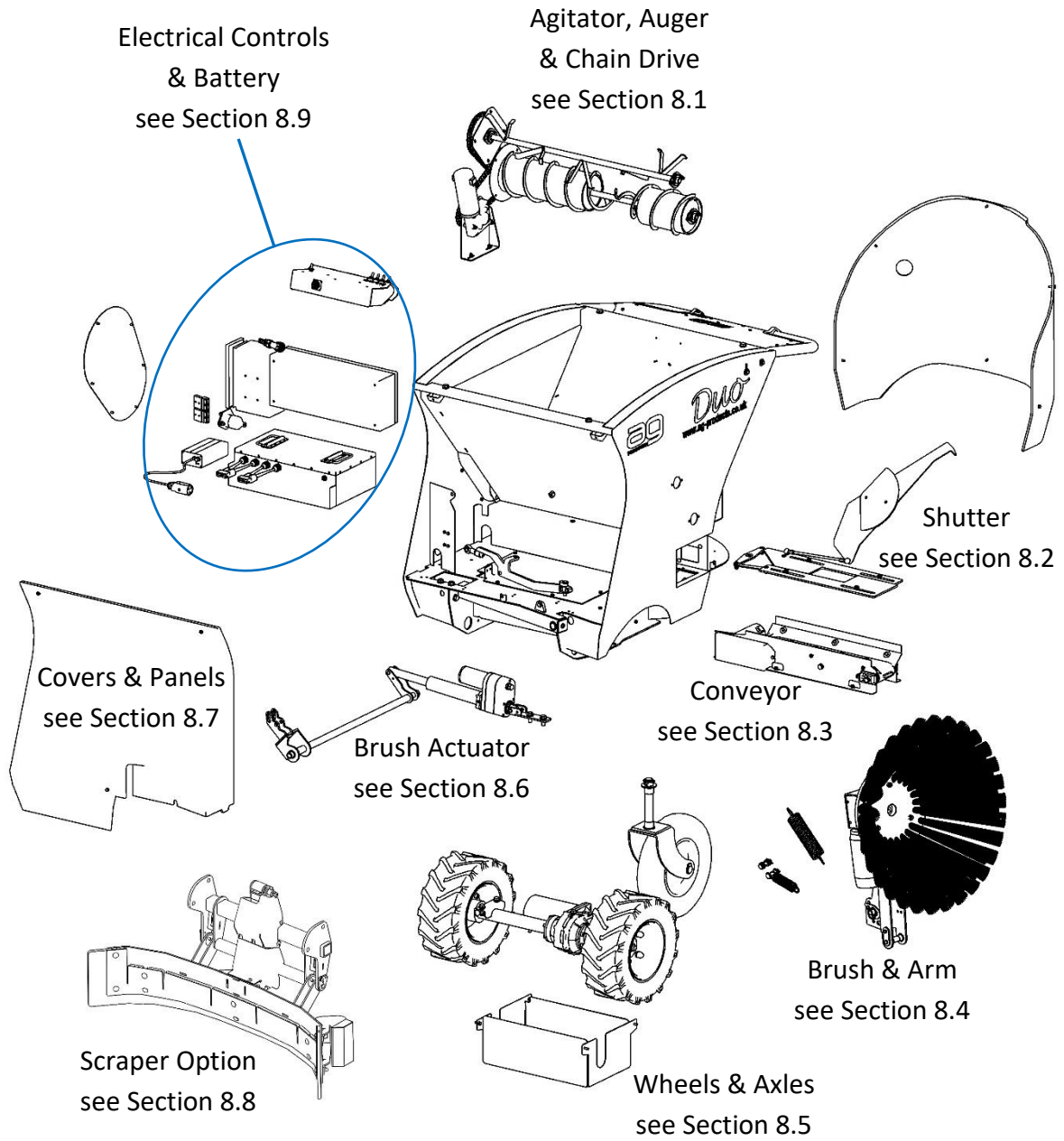

8.1 AGITATOR, AUGER & CHAIN DRIVE

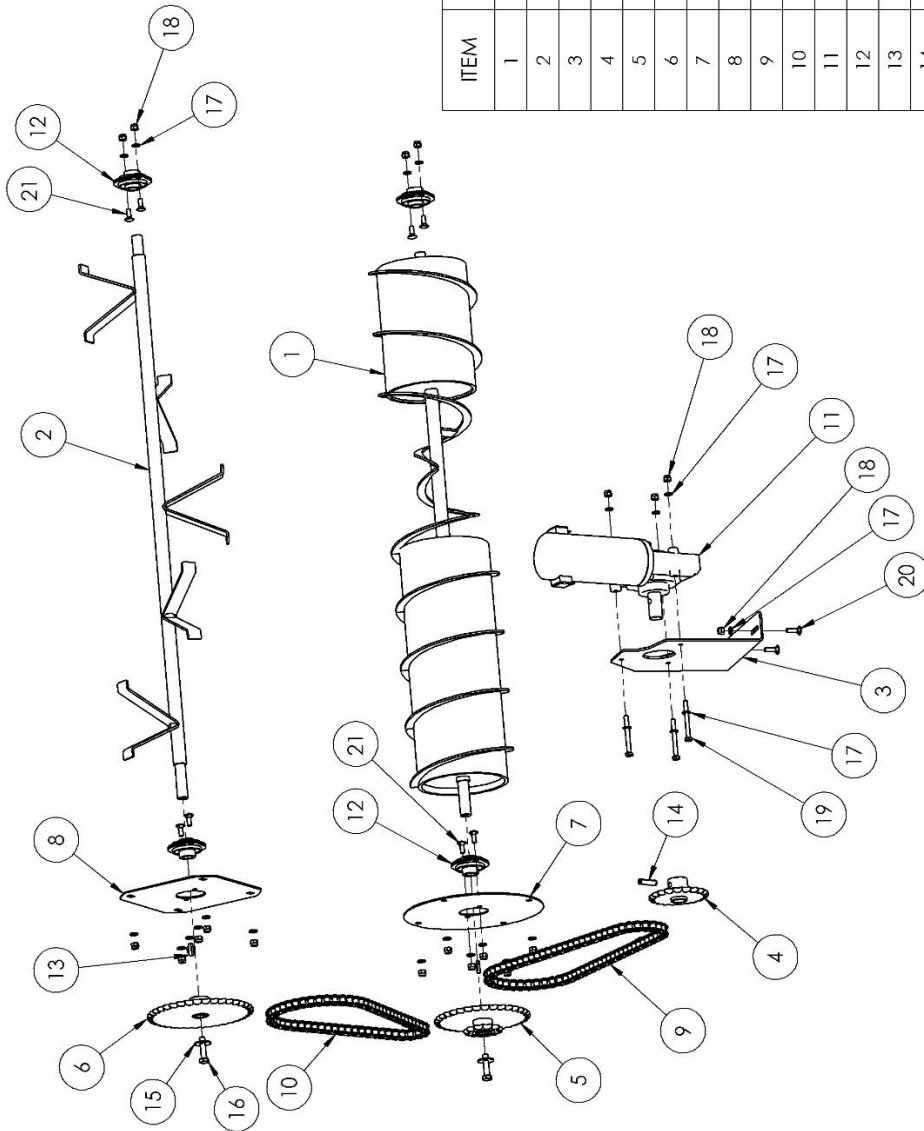

ITEM	PART	PART NUMBER	QUANTITY
1	AUGER	A1420	1
2	AGITATOR	A1423	1
3	AUGER MOTOR BRACKET	A1427	1
4	AUGER MOTOR SPROCKET	A1428	1
5	AUGER SPROCKET	A1429	1
6	AGITATOR SPROCKET	A1430	1
7	AUGER COVER PLATE	P1433	1
8	AGITATOR COVER PLATE	1434	1
9	AUGER CHAIN	P1471	1
10	AGITATOR CHAIN	P1472	1
11	GEARED MOTOR	X50152	1
12	BEARING	X21004	4
13	KEY	X21514	2
14	PIN	X11307	1
15	LARGE WASHER	X11043	2
16	SCREW	x11123	2
17	WASHER	X11029	24
18	LOCK NUT	X11013	21
19	SCREW	X11144	3
20	BOLT	X11130	2
21	BOLT	X11126	8

8.2 SHUTTER

ITEM	PART	PART NUMBER	QUANTITY
22	LINK ROD	A1418	1
23	SLIDER SUPPORT	A1436	2
24	LEFT SLIDE	P1411	1
25	RIGHT SLIDE	P1412	1
26	LEVER	P1414	1
27	LEVER SLIDE SHEET	P1419	2
28	CROSS BAR	P1437	1
29	LINK	P1438	2
30	LARGE WASHER	X11043	2
31	WASHER	X11027	10
32	LOCK NUT	X11006	8
33	SCREW	X11122	4
34	SCREW	X11053	4

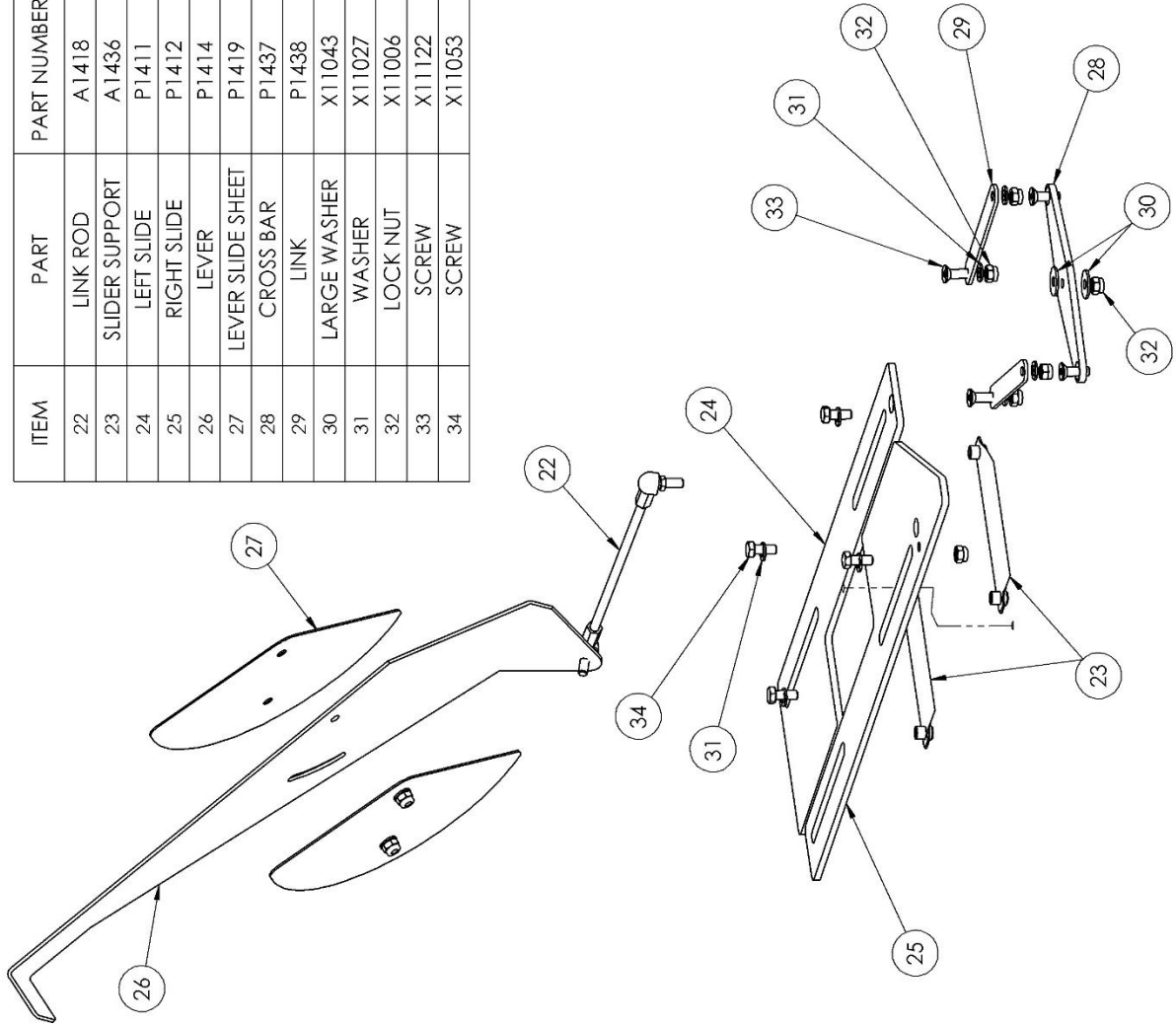

8.3 CONVEYOR

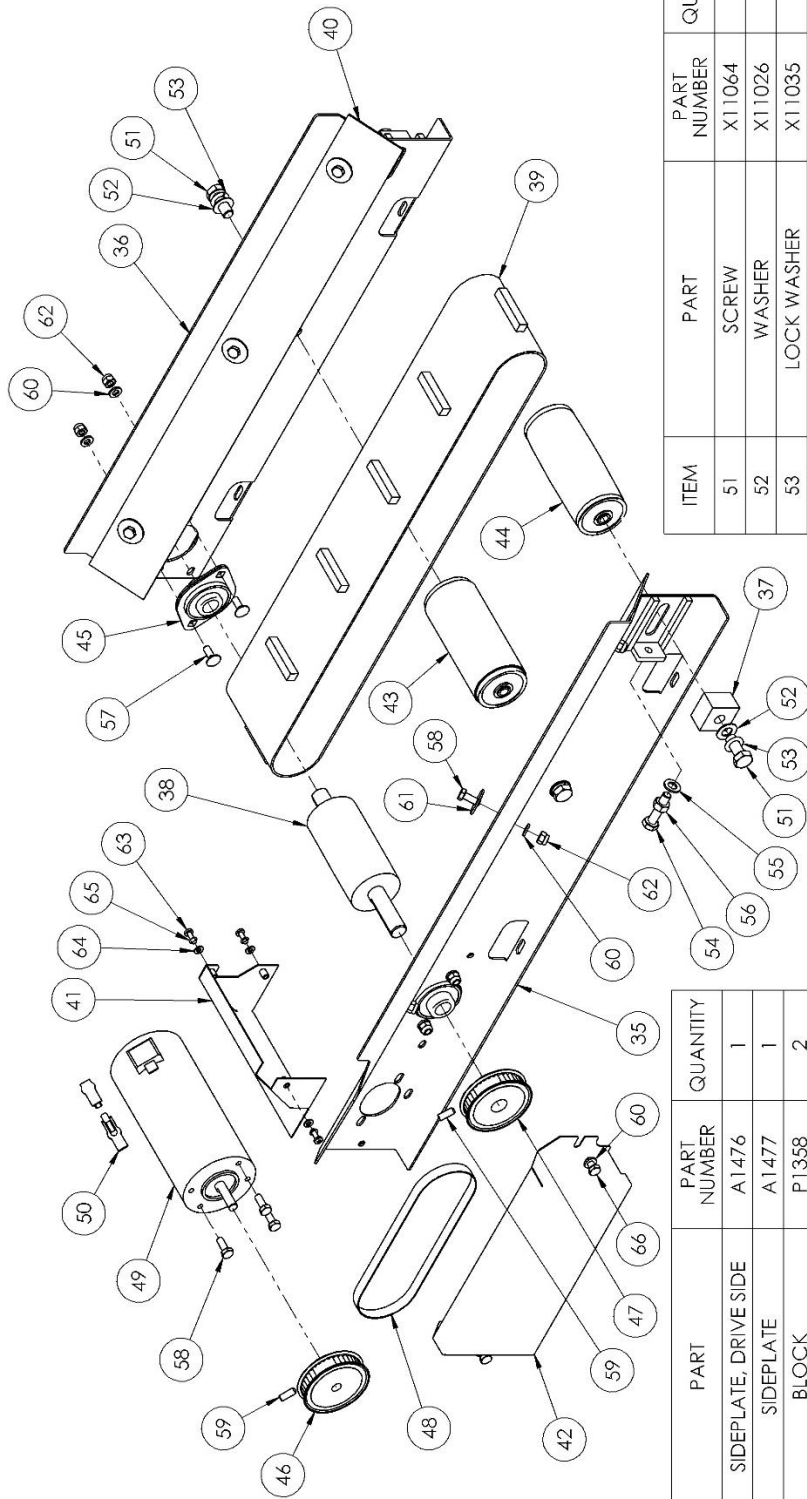

ITEM	PART	PART NUMBER	QUANTITY
51	SCREW	X11064	4
52	WASHER	X11026	4
53	LOCK WASHER	X11035	4
54	SCREW	X11123	2
55	WASHER	X11027	2
56	NUT	X11007	2
57	BOLT	X11126	4
58	SCREW	X11124	9
59	GRUBSCREW	X11127	2
60	WASHER	X11029	12
61	LARGE WASHER	X11045	6
62	LOCK NUT	X11013	10
63	SCREW	X11093	3
64	WASHER	X11038	3
65	LOCK WASHER	X11040	3
66	SCREW	X11062	2

ITEM	PART	PART NUMBER	QUANTITY
35	SIDEPLATE, DRIVE SIDE	A1476	1
36	SIDEPLATE	A1477	1
37	BLOCK	P1358	2
38	DRIVE ROLLER	P1359	1
39	CONVEYOR BELT	P1360	1
40	SKIRT	P1361	2
41	COVER	P1363	1
42	DRIVE BELT COVER	P1478	1
43	STRAIGHT ROLLER	X21013	1
44	PROFIED ROLLER	X21014	1
45	BEARING	X21004	2
46	MOTOR PULLEY	X32301	1
47	DRIVE ROLLER PULLEY	X32302	1
48	DRIVE BELT	X32303	1
49	MOTOR	X50153	1
50	MOTOR BRUSH	X50020	2

8.4 BRUSH & ARM

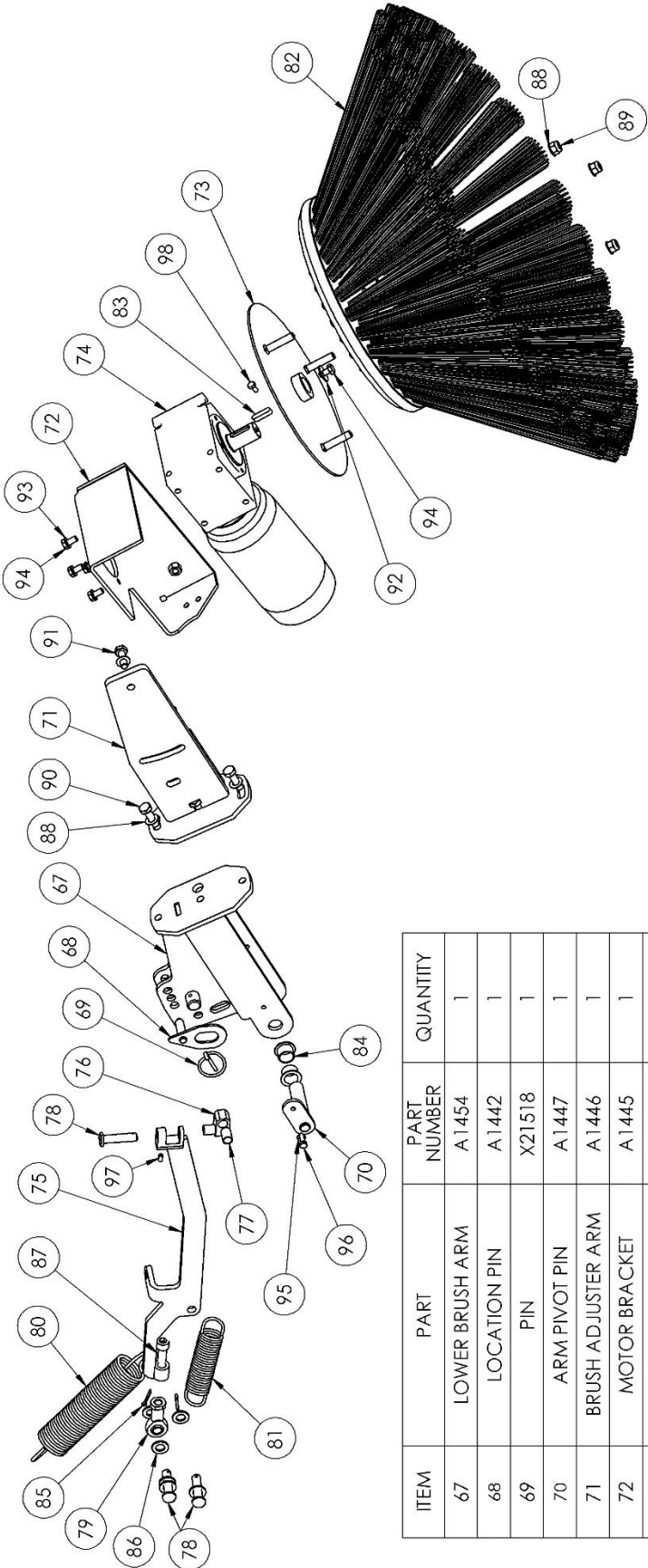

ITEM	PART	PART NUMBER	QUANTITY
67	LOWER BRUSH ARM	A1454	1
68	LOCATION PIN	A1442	1
69	PIN	X21518	1
70	ARM PIVOT PIN	A1447	1
71	BRUSH ADJUSTER ARM	A1446	1
72	MOTOR BRACKET	A1445	1
73	BRUSH PLATE	A1443	1
74	BRUSH MOTOR	X50082	1
75	LINK BAR	A1457	1
76	TRUNNION	P1456	1
77	BUSH	X50155	2
78	PIN	X21517	3
79	JOINT	X50110	1
80	SPRING	P149004	1
81	SPRING	P1499005	1
82	BRUSH	P1441	1
83	KEY	X21513	1
84	BUSH	X50154	2
85	PIN	X21516	2
86	WASHER	X11028	6
87	SCREW	X11077	1
88	WASHER	X11026	8
89	LOCK NUT	X11003	4
90	SCREW	X11057	2
91	SCREW	X11056	2
92	LARGE WASHER	X11043	1
93	WASHER	X11027	4
94	SCREW	X11116	5
95	WASHER	X11029	1
96	SCREW	X11098	1
97	GRUBSCREW	X11145	1
98	SCREW	X11062	1

8.5 WHEELS & AXLES

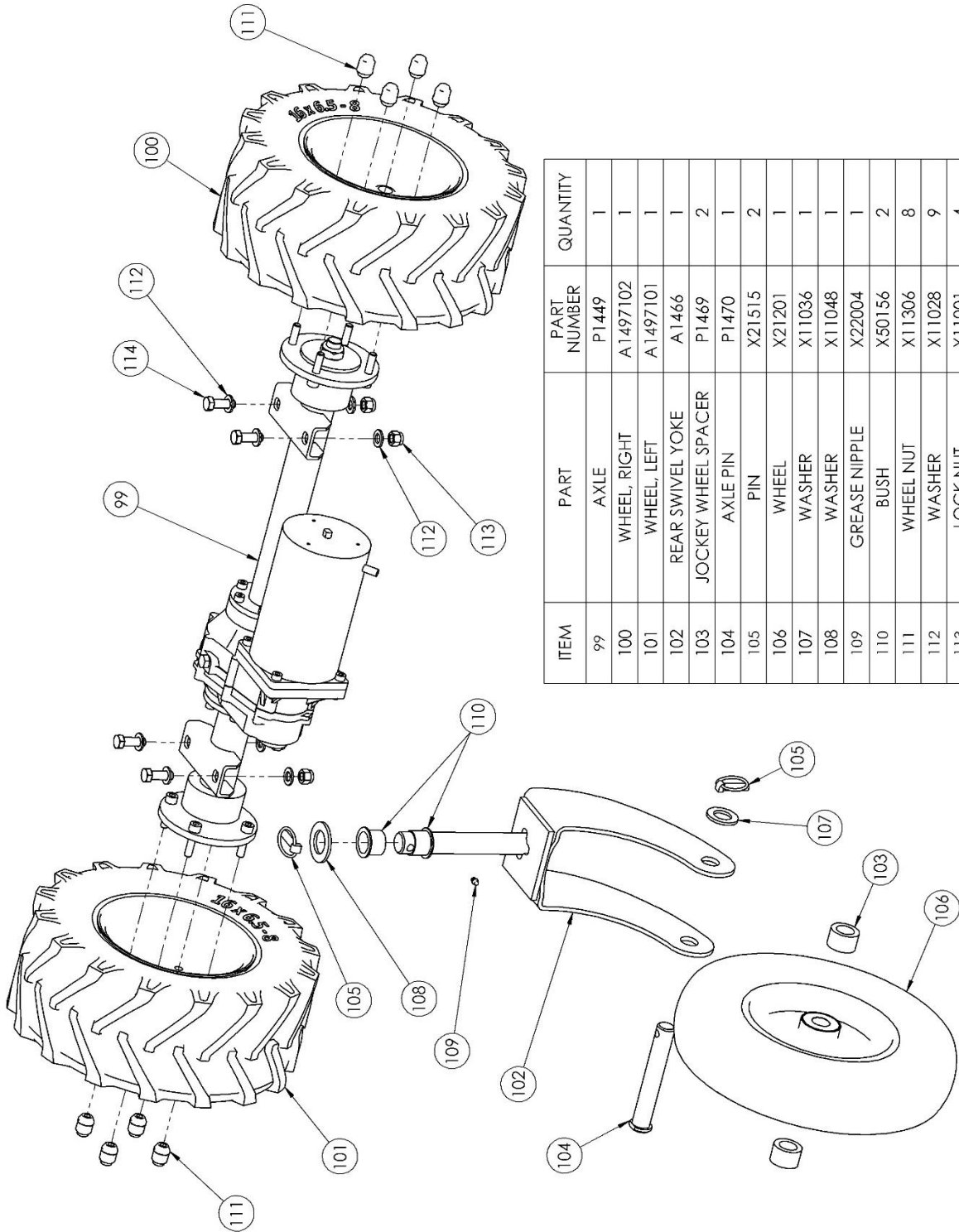

ITEM	PART NUMBER	PART	QUANTITY
99	P1449	AXLE	1
100	A1497102	WHEEL, RIGHT	1
101	A1497101	WHEEL, LEFT	1
102	A1466	REAR SWIVEL YOKE	1
103	P1469	JOCKEY WHEEL SPACER	2
104	P1470	AXLE PIN	1
105	X21515	PIN	2
106	X21201	WHEEL	1
107	X11036	WASHER	1
108	X11048	WASHER	1
109	X22004	GREASE NIPPLE	1
110	X50156	BUSH	2
111	X11306	WHEEL NUT	8
112	X11028	WASHER	9
113	X11001	LOCK NUT	4
114	X11143	SCREW	4

8.6 BRUSH ACTUATOR

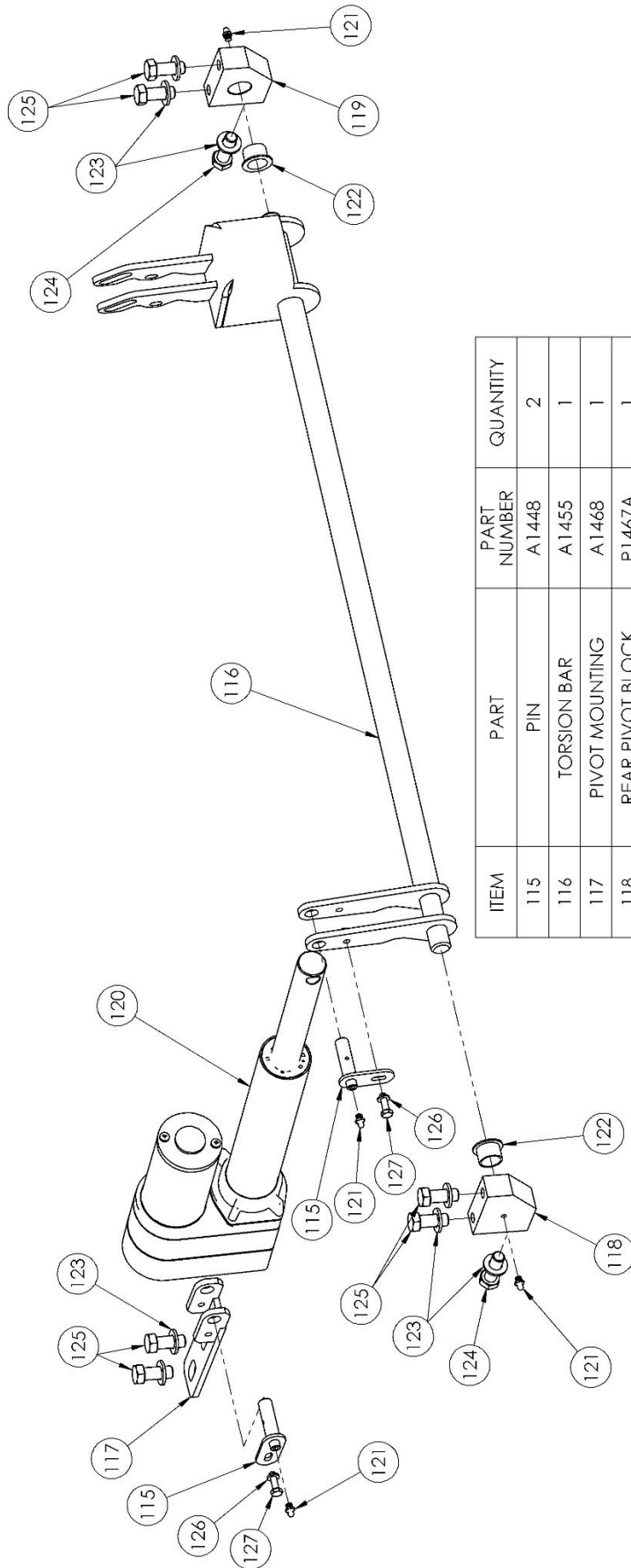

ITEM	PART	PART NUMBER	QUANTITY
115	PIN	A1448	2
116	TORSION BAR	A1455	1
117	PIVOT MOUNTING	A1468	1
118	REAR PIVOT BLOCK	P1467A	1
119	FRONT PIVOT BLOCK	P1467B	1
120	ACTUATOR	X50083	1
121	GREASE NIPPLE	X22004	4
122	BUSH	X50154	2
123	WASHER	X11028	8
124	SCREW	X11083	2
125	SCREW	X11079	6
126	WASHER	X11029	2
127	SCREW	X11098	2

8.7 COVERS AND PANELS

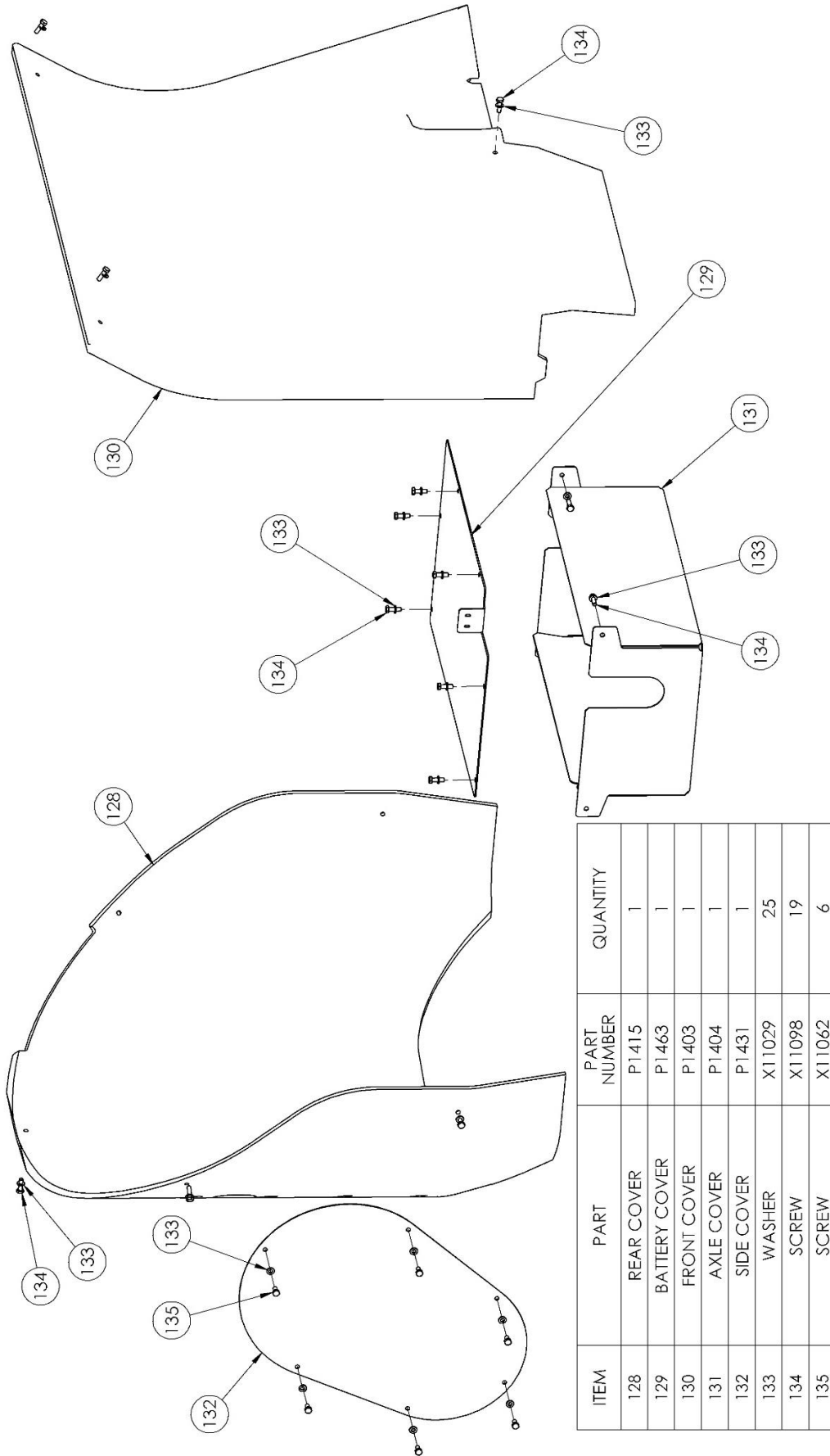

ITEM	PART	PART NUMBER	QUANTITY
128	REAR COVER	P1415	1
129	BATTERY COVER	P1463	1
130	FRONT COVER	P1403	1
131	AXLE COVER	P1404	1
132	SIDE COVER	P1431	1
133	WASHER	X11029	25
134	SCREW	X11098	19
135	SCREW	X11062	6

8.8 SCRAPER (OPTIONAL)

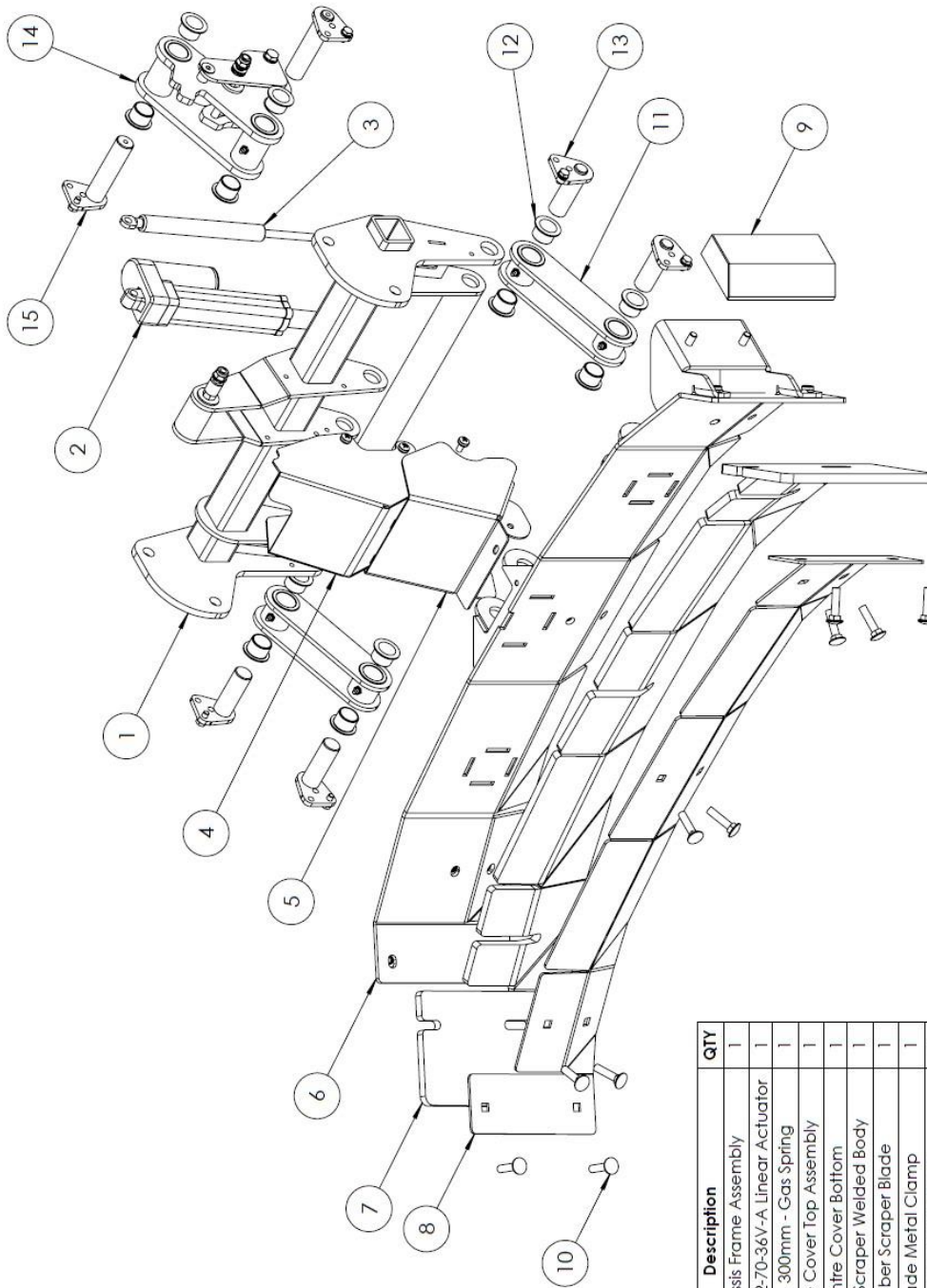

ITEM	PART NO.	Description	QTY
1	A1495006	Chassis Frame Assembly	1
2	X50197	JMK-DT04-T2-70-36V-A Linear Actuator	1
3	X50179	100N - 300mm - Gas Spring	1
4	A1495028	Centre Cover Top Assembly	1
5	P1495031	Centre Cover Bottom	1
6	A1495002	Metal Scraper Welded Body	1
7	P1495004	Rubber Scraper Blade	1
8	P1495005	Blade Metal Clamp	1
9	P1495003	Scraper Skid Block	1
10	X90001	Scraper Blade Fixing Kit 10x M8x35mm Cup Hex Screws (X11069) 2x M8x20mm Hex Set Bolts (X11053) 12x M8 Washers (X11027) 10x M8 Nylock Nuts (X11006)	1
11	A1495007	Outer Arm Link Assembly	1
12	X50154	IGUS Flanged Bush	12
13	A1495027	Outer Arm Locking Pin	4
14	A1495009	Centre Arm Assembly	1
15	A1495014	Centre Arm Locking Pin	2

8.9 ELECTRICAL

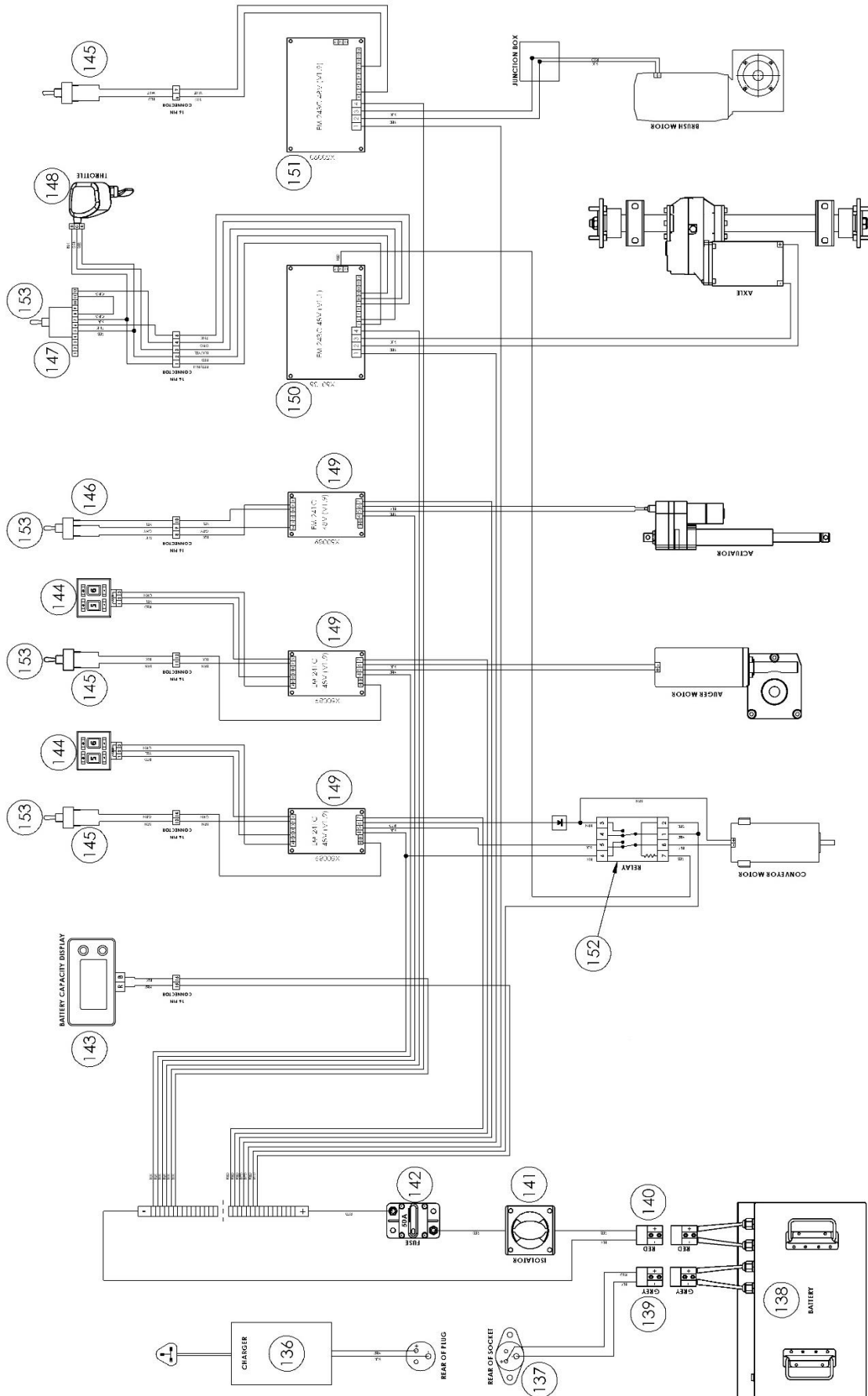

ITEM	PART	PART NUMBER	QUANTITY
136	CHARGER	A1497001	1
137	SOCKET	P1499003	1
138	BATTERY	X50160	1
139	GREY CONNECTOR	X50170	1
140	RED CONNECTOR	X50070	1
141	ISOLATOR SWITCH	X50174	1
142	CIRCUIT BREAKER	X50111	1
143	BATTERY DISPLAY	X50173	1
144	SPEED CONTROL	X50101	2
145	SWITCH	P1496006	3
146	SWITCH	P1496005	1
147	SWITCH	P1496007	1
148	THUMB THROTTLE	X50171	1
149	MOTOR CONTROLLER	X50089	3
150	MOTOR CONTROLLER	X50135	1
151	MOTOR CONTROLLER	X50090	1
152	RELAY	X50175	1
153	SEALING BOOT	X50172	5

9 BATTERY CHARGER OPERATING MANUAL

1. Overview

With CPU control and PWM technology, the charger has the advantages like high efficiency, good stability, low-carbon and energy-saving. Three-section charging mode ---- Controlling the charging current and voltage automatically and precisely, both ensure that battery is charged fully, and not over charged. Your battery life will be protected.

2. Unpacking Inspection

Open the package case, check the items shown on Table 1 carefully to check any missing or damaged part.

Table 1. Unpacking Inspection

Item	Description	Qty
1	Charger	1
2	Operating manual	1
3	AC wire	1
4	Output fuse	2
5	Output Connector	1

3. Charger Model & Parameter

3.1 Model series

Umini 120W 180W 240W 360W
600W 900W 1200W 1500W _____

3.2 Rated input voltage

90-130V 200-240V 100 / 240V

3.3 Constant voltage

12.6V 14.6V 16.8V 29.2V 29.4V
42.0V 43.8V 54.6V 58.4V 58.8V
67.2V 71.4V 84.0V 87.6V ____

3.4 Floating charge voltage (For lead-acid battery)

3.5 Constant current

0.1~5.0A 5.1~10.0A 10.1~15.0A
15.1~20.0A 20.1~25.0A _____

3.6 Light turn green

5-10%CC 20-30%CC _____

4. Operating Instruction

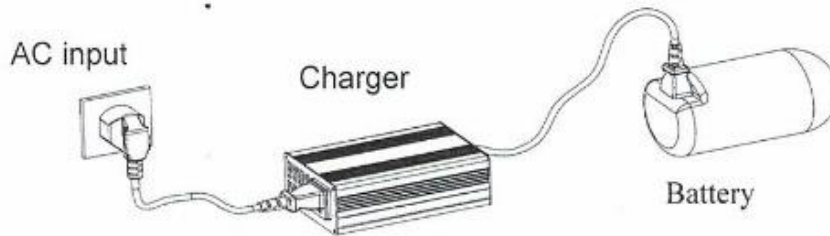

Fig 1. Connection diagram

- 4.1 Before charging, please connect the DC terminal to battery firstly, and then connect the AC terminal.
- 4.2 After charging complete, unplug the AC terminal firstly, and then unplug the DC terminal.
- 4.3 No charging or after charging complete, be sure to unplug the DC terminal and the AC terminal.
- 4.4 LED1, the power on indicator, shows red when the charger starting-up.
- 4.5 LED2, the charging status indicator, shows red during the charger is charging, shows green means the battery is charged complete.

5. Matters Need Attention

- 5.1 Don't cover the charger or intake during charging.
- 5.2 The charger should be placed where children could not touch.
- 5.3 Please charging in indoor area where good ventilation and heat dissipation is. Prohibited charging where is humid, high temperature or a flammable, explosive gas surrounding.
- 5.4 To avoid vibration damage, please don't carry the charger on the driving vehicle long time.
- 5.5 It's danger of high voltage in charger case please do not disassemble it unauthorized.
- 5.6 The losses caused by not operating according to the instruction manual operation, manufacturer does not bear any responsibility.

6. Maintenance

WARNING: Before conducting the following operations, make sure the charger is disconnected with the battery and power connection.

6.1 Routine maintenance

- Clear dust on vents and fan regularly, to ensure the charger has good heat dissipation.
- Periodically wipe the case with a cloth with some alcohol.
- Do not use or store the charger in a place of humidity or high temperature.

6.2 Replace the fuse

If the charger can not charge, please confirm the output fuse is blown out. Install only replacement fuse with the identical type and specification as follows and make sure the fuse is fixed firmly in the fuse holder.

6.3 Common malfunction & Solution

Phenomenon	Cause	Solution
After connecting charger and battery, charger can not work or, LED2 shows green.	Connecting reverse, output fuse blow.	Please replace the fuse, and then connect charger and battery correctly.
	Connecting reverse, relay has no action.	
Battery isn't charged fully, but LED2 flashes between red and green.	Charger and battery is disconnected.	Reconnect charger and battery.
	Charger overheating, into thermal protection mode and standby.	Cooling charger, Charger can auto-resume to work when temperature cool down.
After connect charger to AC power, charger can not work, and two LED don't light.	Plug loose, charger does not connect to AC power.	Reconnect the AC wire, and make sure that is OK.
	Charger has damaged	Send charger back to local dealer for repair. There is high-voltage inside charger, please don't open the charger personally.

10 TERMS, CONDITIONS AND WARRANTY

10.1 STANDARD TERMS AND CONDITIONS

Garnett Farms Engineering Limited

These terms and conditions and any dispute or claim arising out of or in connection with them shall be governed by and construed in accordance with English law, and the parties submit to the exclusive jurisdiction of the English courts.

TERMS AND CONDITIONS OF BUSINESS (HOME MARKET)

Definitions

“The Company” means Garnett Farms Engineering Limited. “The Customer” means the Company, organisation, firm or person whose order for goods is accepted by the Company.

General

All quotations given and orders accepted by the Company are subject to these terms and conditions of business. All other terms, conditions and modifications are excluded unless agreed to in writing by the Company.

Specifications

The Company’s policy is one of continuous improvement and development. Specifications and prices are therefore subject to change without notice. Published descriptions of goods are intended to provide a general idea of the goods and shall not constitute a sale by description.

Prices

All price lists previous to that which is the latest at the time of ordering are cancelled. Except for specific equipment as listed in the current price list, prices for machines include delivery to the dealer’s premises in mainland Britain. Where whole or part carriage is chargeable, details of rates and machines involved are given in the price list currently applicable. Delivery of spare parts is chargeable and is dependent upon the method of transport requested by the Customer at the time of ordering. The minimum invoice charge, excluding VAT, is £10.

Listed prices and delivery charges do not include VAT or any other tax or levy on the supply of goods, which will be an additional charge to the Customer.

Payment Terms

Unless otherwise agreed in writing at the time of ordering, payment terms will be strictly in line with the published Marketing Strategy current at that time. If payment is not made by the due date, the Company shall be entitled to charge interest on the outstanding amount at 4% above the current Bank Base Rate, accruing daily.

Late payment of special nett or early payment invoices may incur a single surcharge of 5% by way of loss of discount.

Delivery

Delivery of machines will be scheduled depending upon Company transport, but every attempt will be made to meet the customer's requirements. Delivery dates specified verbally or in writing are approximate only.

The method of transport required for the delivery of spare parts must be specified at the time of ordering. The Company accepts no liability for delay in delivery or the consequences of any such delay howsoever caused.

The Customer must notify the Company immediately upon receipt of the goods of any damage, shortage, or errors in delivery. Non-receipt of goods must be notified within 7 days of receipt of invoice unless the invoice specifically refers to an early payment scheme. The responsibility for the goods will pass to the Customer from the time of delivery.

Title

All goods remain the property of the Company until the Customer has paid in full the whole of the contract price. While the goods remain the property of the Company, the Customer shall keep them in good condition and insure them against damage or theft. They shall be returned to the Company upon demand. Any proceeds from an insurance claim in this connection shall belong to the Company for whom the Customer shall hold the same in trust. The Customer is prohibited from creating any mortgage, charge, lien or other encumbrance adverse to the title of the Company.

The Customer will keep the Company's goods separately identifiable and if the goods are resold, the Customer will have the fiduciary duty to account to the Company for the proceeds of the sale.

Returns

No goods will be accepted for credit by the Company without prior agreement. Any goods accepted for credit shall be returned at the Customer's expense and will be subject to a 10% handling charge unless otherwise agreed.

Warranty

The guarantee is in addition to and does not affect a purchaser's statutory rights.

Garnett Farms Engineering Limited products carry a 12-month Parts and Labour Warranty. Certain products carry an extra warranty as specified in the relevant sales literature. Components supplied as part of the original machine, but manufactured by another company e.g. PTO shafts, wheels etc., are subject to the original manufacturer's condition of warranty. Failure of wearing parts due to "Fair Wear and Tear" is not covered by the terms of the warranty.

The Warranty is invalidated by misuse, neglect and improper repairs or adjustment. The warranty does not cover fire or accidental damage.

The right to withdraw warranty is reserved if:

Non-original parts are fitted;

The machine has been abused, badly maintained or used for purposes other than that for which it was intended.

When ordering parts under warranty, this must be made clear at the time of ordering, giving the serial number of the machine (where appropriate) and the date of purchase. The parts will either be supplied free of charge or invoiced then credited upon receipt of the defective parts if the claim is accepted.

The cost of carriage of parts supplied under warranty will be paid by the Company except where express delivery is requested by the Customer. Under such circumstances, the Company reserves the right to charge for the cost difference between express and normal transport.

Parts replaced under warranty shall become the property of the Company and the return of those parts for inspection may be requested. Payment for the parts and carriage will be due in the event of the failure being found to be outside the terms of the warranty.

An agreement and an authorisation number must be sought from the Company by the repairer before warranty repairs are commenced. Warranty claims will not be considered without a valid authorisation number.

Credit cannot be issued for parts not supplied by the Company unless there has been a prior agreement for the use of those parts. Where such agreement exists, the credit given will normally exceed the value which would have been invoiced if the parts had been obtained from the Company.

Warranty claims must be submitted within four weeks of the repair.

Standard rates apply for credit of claims for labour and travelling (up to a maximum of 30 miles).

Parts fitted outside of the machine's warranty period carry a 3-month warranty on parts only. The warranty cannot be transferred to the initial purchaser.

Except as mentioned above, no condition of warranty, collateral warranty or representation as to the goods or their quality, design, specification, performance or fitness for a particular purpose if given by the Company or shall be implied into the sale of goods by law. The Company shall not be liable, whether in contract, tort or otherwise for any loss, damage, expense or injury (except personal injury or death) whether to person or property, howsoever caused and whether direct or consequentially suffered by the Customer, his employees, agents or any third party arising out of the contract for the sale of the goods, the goods supplied, or work done by the Company.

To qualify for the full benefit of this warranty, the dealer must ensure that the warranty registration details have been returned to Garnett Farms Engineering Ltd within 30 days from the date of delivery. Using the machine implies the knowledge and acceptance of these instructions and the limitations contained here in this manual. Garnett Farms Engineering Ltd reserves the right to suspend the operation of these warranty conditions unless and until the purchaser has paid in full for the goods or parts in question.

10.2 QUALITY OF TRANSLATIONS

Where instructions for use are translated from these Original Instructions into other languages, expert translators or specialists shall be responsible for the translation, including editing and proofreading, and:

- have basic competences in communication, particularly technical communication.
- be familiar with the subject area.
- be fluent in the original and target languages, preferably native speakers in the target language.

Colloquial expressions and untypical regional variations of names and product features should be avoided.

Translated instructions should be clearly marked as translations of the Original Instructions.

10.3 SAFETY

It is the responsibility of the dealer to ensure the end-user is handed the instruction book and receives adequate training in the safe use of the machine.

10.4 AG PRODUCTS DEALER WARRANTY PROCESS

Warranty Registration

Form must be completed: <https://www.ag-products.co.uk/warranty-registration-form/>

within 30 days of purchase. The warranty must be registered to the end user.

Warranty Claim

To make a claim under warranty

- Diagnose the fault via the telephone with the customer and attend the breakdown with likely parts required to fix the fault.
- Take pictures of the serial number of the machine, any failed parts, and general pictures of the machine.
- Email the completed warranty claim form with corresponding photos to service@ag-products.co.uk within 30 days of identification of the fault.
- All failed parts must be held for 3 months unless instructed by AG Products
- AG Products aim to process and credit where applicable all claims within 60 days of submission of the warranty claim.

Exceptions to Warranty Cover

- **Damage or depreciation caused by normal wear and tear. Parts which have been subject to alteration, modification, or fitment of non-genuine AG Products parts, wilful or accidental damage, damaged caused by foreign objects (e.g. stones, metals, and any other materials other than suitable for the machines intended use).**
- **Damage or depreciation caused by neglect or failure to carry out proper maintenance as recommended in operators manual.**
- **Damage or depreciation caused by abnormal or improper use in accordance with AG Products recommendations and/or as per the operating manual.**
- **Environmental damage**

Key Contacts

Warranty Claims

Alex Riley

t. 01565 722922

e: service@ag-products.co.uk

Parts Orders

Gareth Woofitt

t. 01565 722922

e: dispatch@ag-products.co.uk

